



Our ref.: LES/J2018-05/CS/L018  
Date : 7 December 2018

**Civil Engineering and Development Department**

East Development Office  
East Division 2  
Suite 1213,  
Chinachem Golden Plaza,  
77 Mody Road,  
Tsim Sha Tsui East, Kowloon

**Attn: Mr. Henry Lu**

Dear Mr. Lu

**Service Contract No. EDO/01/2017  
ENVIRONMENTAL TEAM FOR  
Development of Anderson Road Quarry Site –  
Road Improvement Works**

**Submission of Transplantation Proposal**

We hereby submit the captioned report which certified by the ET Leader and verified by IEC in accordance with Condition 2.14b and 2.15 of EP-513/2016 for your perusal and processing.

Should you have any queries, please contact the undersigned at 9108 0531.

Yours faithfully,  
For and On Behalf Of  
**Lam Environmental Services Limited**

A handwritten signature in blue ink, appearing to be "DL" or similar initials.

Derek Lo  
Environmental Team Leader

Encl.

c.c. AECOM  
ANewR Consulting Limited

Mr. Dennis Leung  
Mr. Adi Lee



Civil Engineering and Development Department  
Civil Engineering and Development Building  
101 Princess Margaret Road  
Kowloon  
Hong Kong

Your reference:

Our reference: HKCEDD12/50/105396

Date: 3 December 2018

Attention: Mr Stephen T S Li

**BY EMAIL & POST**  
**(email: [tqli@cedd.gov.hk](mailto:tqli@cedd.gov.hk))**

Dear Sirs

Agreement No. EDO/04/2017  
Independent Environmental Checker (IEC) for Development of Anderson Road Quarry Site  
– Road Improvement Works  
Transplantation Proposal

---

We refer to the emails on 26 September, 25 October, 28 November and 5 December 2018 from the Environmental Team, Lam Environmental Services Limited attaching a Transplantation Proposal for the captioned project.

We have no further comment and hereby verify the abovementioned Transplantation Proposal in accordance with Clause 2.15 of Environmental Permit No. EP-513/2016.

Should you have any queries, please do not hesitate to contact the undersigned or our Ms Angie Chan on 2618 2831.

Yours faithfully  
ANewR CONSULTING LIMITED

Adi Lee  
Independent Environmental Checker

LYMA/LHHN/CWA/lhnh

cc AECOM – Ms Susan He (email: [c2-re5@arqacom.com](mailto:c2-re5@arqacom.com))  
AECOM – Mr Brad C W Chan (email: [c3-srec4@arqacom.com](mailto:c3-srec4@arqacom.com))  
Lam Environmental Services Limited – Mr Derek Lo (email: [dereklo@lamenviro.com](mailto:dereklo@lamenviro.com))



**CONTRACT NO: NE/2017/03**

**DEVELOPMENT OF  
ANDERSON ROAD QUARRY SITE -  
ROAD IMPROVEMENT WORKS**

**TRANSPLANTATION PROPOSAL**

**CLIENTS:**

Civil Engineering and Development Department

**PREPARED BY:**

Jay WAN  
Qualified Ecologist

**CERTIFIED BY:**

Derek LO  
Environmental Team Leader

**Lam Environmental Services Limited**

11/F Centre Point  
181-185 Gloucester Road  
Wanchai, H.K.

Telephone: (852) 2882-3939  
Facsimile: (852) 2882-3331  
E-mail: [info@lamenviro.com](mailto:info@lamenviro.com)  
Website: <http://www.lamenviro.com>

**DATE:** 3 December 2018

# **Transplantation Proposal for Contract No. NE/2017/03 Development of Anderson Road Quarry Site – Road Improvement Works and Pedestrian Connectivity Facilities Works Phase 2A**

## **1. INTRODUCTION**

Lam Environmental Services Limited was appointed by Civil Engineering and Development Department (CEDD) to conduct a detailed vegetation survey as required in Clause 2.14 and 2.15 of the Environmental Permit No. EP-513/2016 for Contract No. NE/2017/03 Development of Anderson Road Quarry Site – Road Improvement Works and Pedestrian Connectivity Facilities Works Phase 2A.

A total of 51 plant individuals, including two *Aquilaria sinensis* (土沉香) trees and 49 seedlings were recommended for transplantation according to information from the separately submitted vegetation survey report. They include two trees R-T02142-(T) and R-T02157-(F), as well as 49 seedlings A1–A32, A37–A53 at Clear Water Bay Road/ On Sau Road site. Their measurement and condition is detailed in **Table 1**.

This transplantation proposal is prepared by Plant Specialist of the Environmental Team in order to provide information on the location and preparation of the receptor site, methodology and implementation programme of transplantation, a 3-year post-transplantation monitoring and maintenance programme.

The approved transplantation works should also be supervised by Plant Specialist of the Environmental Team with relevant experience in transplantation flora species of conservation importance.

## **2. METHODOLOGY**

### *2.1 Transplantation Guidelines Followed*

Transplantation process shall follow guidelines and relevant clauses in CEDD's *General specification for Civil Engineering Works Volume 1* (2006) (GS) and Particular Specification (PS) of the Contract. Works on "Tree Transplanting" shall follow Clauses GS3.97, PS3.97-3.103 and PS Appendix 3.1); while "Establishment Works" shall follow GS3.79-3.93 and PS3.79-3.92C (PS Section 3 and Appendix 3.1 are attached as **Appendix A**); as well as *Guidelines on Tree Transplanting* (2014) from Greening, Landscape and Tree Management Section, Development Bureau (GLTM) wherever applicable.

## *2.2 Receptor Sites*

Candidates of receptor site that selected from desktop review were verified during the detailed vegetation survey. By considering a balance among tree size to be transplanted, limitations in logistical practicability, resource availability, habitat suitability for the transplanted trees, and effectiveness of the post-transplantation monitoring, two receptor sites were come in agreement with the Supervisor and Contractor during the joint site visit on 4 September 2018.

Proposed receptor site for the mature trees R-T02142-(T) and R-T02157(F) would be the semi-shaded ground opposite to the slope toe where the tree originated, across Clear Water Bay Road. It is named as RSA hereafter (**Figure 1a, 1b and Plate 1**).

Despite RSA locates within the exact Works Site boundary, there will be no construction activities to be carried at this roadside belt of ground (indicated generally by **Figure 1b**; detailed works drawing to be supplemented by the Engineer separately) and hence there would be no direct impacts to the site.

Potential indirect impact includes leaking of excavated soil and runoff generated from slope cutting works to RSA. Such indirect impact can be avoided by enclosing RSA by robust barrier against accidental encroachment of construction activities/ materials. Mobilization and deposition route of slope cutting materials/ equipment shall be clearly defined away from RSA. Good site practice to control runoff should be implemented. No significant indirect impacts would be anticipated to RSA when all mitigation measures are properly implemented according to the approved EIA Report No. AEIAR-195/2016; Environmental Permit No. EP-513/2016 and EM &A Manual.

By considering better microhabitat, further distance from traffic road, and adequate planting space; proposed receptor site for the 49 seedlings is an edge of a continuous secondary woodland patch near Po Lam Road, named as RSB hereafter (**Figure 1a, 1c and Plate 1**).

## *2.3 Receptor Sites Preparation*

All 51 plants to be transplanted would be planted near or under existing canopy of the receptor sites on semi-shaded ground with no or less ground vegetation cover. Disturbance to existing vegetation should be minimized only for planting pit preparation, ground clearance for temporary access or stock-piling of top soil dug from planting pits.

Locations of each planting pits should be agreed by the Plant Specialist and the Supervisor of the Contract with adequate spacing for sustainable survival of mature tree or future growth for the seedlings. RSA is large enough to settle two mature trees R-T02142-(T) and R-T02157; while a minimum of 1.5m spacing is suggested for the 49 seedlings to be transplanted at RSB. Exact pit locations will be directed on site with approval of the Plant Specialist and agreed by the Supervisor of the Contract.

### *2.3.1 RSA for the mature trees R-T02142-(T) and R-T02157*

Any concrete/ pave surface on the ground should be removed. Compacted soil should be loosened over as large an area of the site as possible. Effective percolation of excessive water should be allowed by provided drainage at the planting pit.

Sandy or poor soil should be replaced by fertile soil with more organic matter. Existing topsoil excavated from the same woodland slope to be cut under works activities should be put aside for reuse in order to provide a similar interface between the receptor site and the original growing location.

Soil-mix delivered and installed on site shall be tested for nitrogen, phosphorus and potassium (N.P.K.) value, organic matter content, cation exchange capacity ratio, organic carbon, pH value, physical content of sand, silt and clay, and water content. Requirement of soil mix, soil container and mulch shall refer to GS and Contract PS Clause 3.30 – 3.32.

### *2.3.2 RSB for the 49 Seedlings*

Right before digging of any planting pit, the Plant Specialist should confirm whether this receptor site at natural patch of secondary woodland contains any plant species of conservation importance. Any detected plant species of conservation importance should be fenced off to prevent from damage during transplantation works.

### *2.3.3 Plantation Pits*

Planting pits should be ready prior uplifting/ transplantation of the plant. The optimum pit size is two to three times the width; and same depth of the rootball at the surface. This allows root growth vigorously toward the better soils near the surface rather than being trapped in the planting hole. Soil directly beneath the root ball should be undistributed to prevent settling.

### *2.4 Plant Preparation*

Since all 51 plant individuals to be transplanted have been tagged during detailed vegetation survey. Any lost tag should be replaced right before transplantation.

All the seedlings A1-A32 and A37-A53 should be dug up and transplanted before preparing the rootball of mature trees R-T02142-(T) and R-T02157.

Since size of all 49 seedlings is small, with height ranging from 0.14–1.07m and stem size around 1cm or below, no crown pruning should be conducted.

For the seedlings, rootball diameter is suggested at minimum 150-200mm, with larger size for taller seedlings. The rootball should contain the tap-root, most lateral roots and absorbing roots as far as possible. Any unavoidable root cuts would be cleaned and trimmed sharply from tearing tissues to healthy tissues.

The seedlings should be dug up by a hand-held shovel by Landscape Specialist Contractor. Whole root ball will be dug out with holding the stem base above soil layer but not simply pulled out by forcing the stem.

Rootball diameter of the mature trees R-T02142-(T) and R-T02157 is suggested at minimum 1500mm with a depth of 1000mm in balancing maximized root system in the root ball thus post-transplantation survival against logistical practicality. Details and contract requirements shall follow Contract PS Clause 3.98.

Root pruning is required before transplanting the mature trees R-T02142-(T) and R-T02157. Sufficient time should be allowed between preparation and final lifting for development of new roots capable of a sustainable and continuous growth at the receptor site, and preventing severe die-back of the crown due to excessive root loss. This can be achieved by stage digging, a process by which portions of the rootball are dug over a period of time in order to allow the tree to acclimate to the stresses gradually.

The four stages are extracted from GLTM's guideline mentioned in Section 2.1 as follow, and illustrated in **Figure 2**:

- 1st stage – Dig a trench on the outside of the marked circumference in only two opposing segments;
- 2nd stage – After a period of no less than 1 month since the 1st root pruning, dig a trench on the outside of the marked circumference in the adjacent two opposing segments;
- 3rd stage – After another period of no less than 1 month since the 2nd root pruning, dig a trench on the outside of the marked circumference, in the remaining two opposing segments; and
- 4th stage – After a further period of not less than 1 month since the 3rd root pruning, prepare the root ball and cut the underside of the root ball, followed by uplifting and transplanting

Root pruning would follow Contract PS Clause 3.98 (1). It should be carried out during wet season with minimum of one month between each stage of root pruning to allow root regeneration before lifting. Since the trees to be transplanted are of rare and precious tree species under law protection (AFCD, 2003), if tree condition is found dropped after any of the four stages, period between each remaining stage shall immediately be extended at minimum

of three months by the Plant Specialist of the Environmental Team and agreed by the Supervisor of the Contract. Trench size shall be at least 300mm wide and 1000mm deep (GS Clause 3.97(4)).

Roots in rootball shall be cut free of ground, not pulled, with a sharp cut. Any unavoidable root cuts would be cleaned and trimmed sharply from tearing tissues to healthy tissues. Cut roots greater than 50mm diameter shall be treated with approved sealant.

All dug up plants should be transferred to a robust container and transport to corresponding receptor site as soon as possible. Desiccation stress should be minimized by covering the container with moistened burlap, or wrapping the rootball with damp hessian.

Tree planting detail (section A-A) and bamboo stacking detail shall also follow Contract drawing No. 60328348/R&P/1951 (attached as **Appendix A**).

### *2.5 Transportation and Planting*

Plant lifting, transportation and planting should only commence until the receptor site is fully prepared; and must be carried out during early morning or late afternoon within the same day when the sun is not directly overhead. Watering before lifting is recommended but no lifting shall take place during rainfall. Operation should allow direct delivery to the receptor site without delay. Tree shall be transplanted within 2 hours of lifting. Details and contract requirements shall follow Contract PS Clause 3.99 –3.100.

In case a holding nursery for transplanted is needed, the Contractor's holding nursery should meet those requirements stipulated in PS Clause 3.101a, regarding to the general condition, storage of transplanted trees, submission of record and tree transplanting within the holding nursery.

If the mature trees R-T02142-(T) and R-T02157 are too tall to be transplanted in the upright position and is put horizontally in transporting vehicle, trunk/ crown support may be necessary such that the rootball may not be flattened during transportation. Tree injury or breaking of soil ball should also be avoided with care.

For the mature tree R-T02142-(T) and R-T02157, it is not recommended to significantly prune the trees to fit in transport vehicles. Retaining the crown can protect the trees against excessive sunlight, wind and drought. Crown cleaning is mainly aim at removing unhealthy, damaged, diseased, dead and crossed branches to minimize susceptibility to pests and diseases. Crown wrapping can prevent branch damage and over-heating due to loss of foliage.



All plants should be planted in upright position in their corresponding planting pits; the root collar should be at or slightly above the finished ground level.

Landscape Specialist Contractor would carry out common practice of planting, i.e. mixing the dug topsoil with compost before backfilling, tamping firmly around the pit base to stabilize the transplanted plant, watering the rootball and backfill materials. Applications of fertilizer and root activator should be determined by the Landscape Specialist Contractor and follows Contract PS Clause 3.34, 3.37A and 3.97 (7).

A soil saucer should be formed around the rootball circumference to allow slow infiltration of rain/ irrigation water into the root zone. Mulching should be placed around the rootball circumference 150mm away from root collar.

Photo record will be taken for each individual after being transplanted.

### **3. IMPLEMENTATION PROGRAMME OF TRANSPLANTATION**

Transplantation should be undertaken prior to the commencement of works in vicinity. Schedule between March and June are preferable when both temperature and rainfall are more adequate when compared to dry season. Suitable temperature and rainfall encourage newly transplanted plants to establish anchorage and feeding roots. Typhoons occasionally hit Hong Kong in summer time which would adversely affect the settlement of the transplanted individuals. Hence we prefer to complete the transplantation before August and September which are the high seasons for typhoons. Detail transplantation programme prepared by the Contractor based on works programme/ progress should get approval from the by the Supervisor of the Contract before implementation.

The receptor sites shall be secured by appropriate barrier or fence against accidental encroachment during construction phase and as kind of protection from illegal loggers.

### **4. THE 3-YEAR POST-TRANSPLANTATION MONITORING & MAINTENANCE**

#### *4.1 Watering*

All transplanted tree/ seedlings shall be well watered only in the evening and early morning on a daily basis (within working hour of the site) in the first three months and during dry season (September to April) since transplantation completed, except rainy day. Based on the monthly monitoring results, the Plant Specialist from the Environmental Team may advise to extend the watering period and the length of extension period according to plant and weather condition by that time (e.g. sign or desiccation and prolonged drought period in wet season). Details and Contract requirements shall also follow PS Clause 3.102.

Water should be applied using a rose or sprinkler agreed by the Supervisor of the Contract. While root zone is totally wetted; either compaction, washout of soil, or loosening of plants should be avoided. Any defects caused shall be repaired immediately.

Construction dust should be minimized and those on leaves should be sprayed off as recommended in Section 4 detailed vegetation survey.

#### *4.2 Other Maintenance for Healthy Growth*

Rootball areas shall be free from weeds at all time while native vegetation outside the planting pits should not be cleared or disturbed. Weeding is carried out by hand or machinery agreed by the Supervisor of the Contract, such that no damage to the transplanted plants would be caused. Chemical or fire weeding should not be allowed under this transplantation proposal.

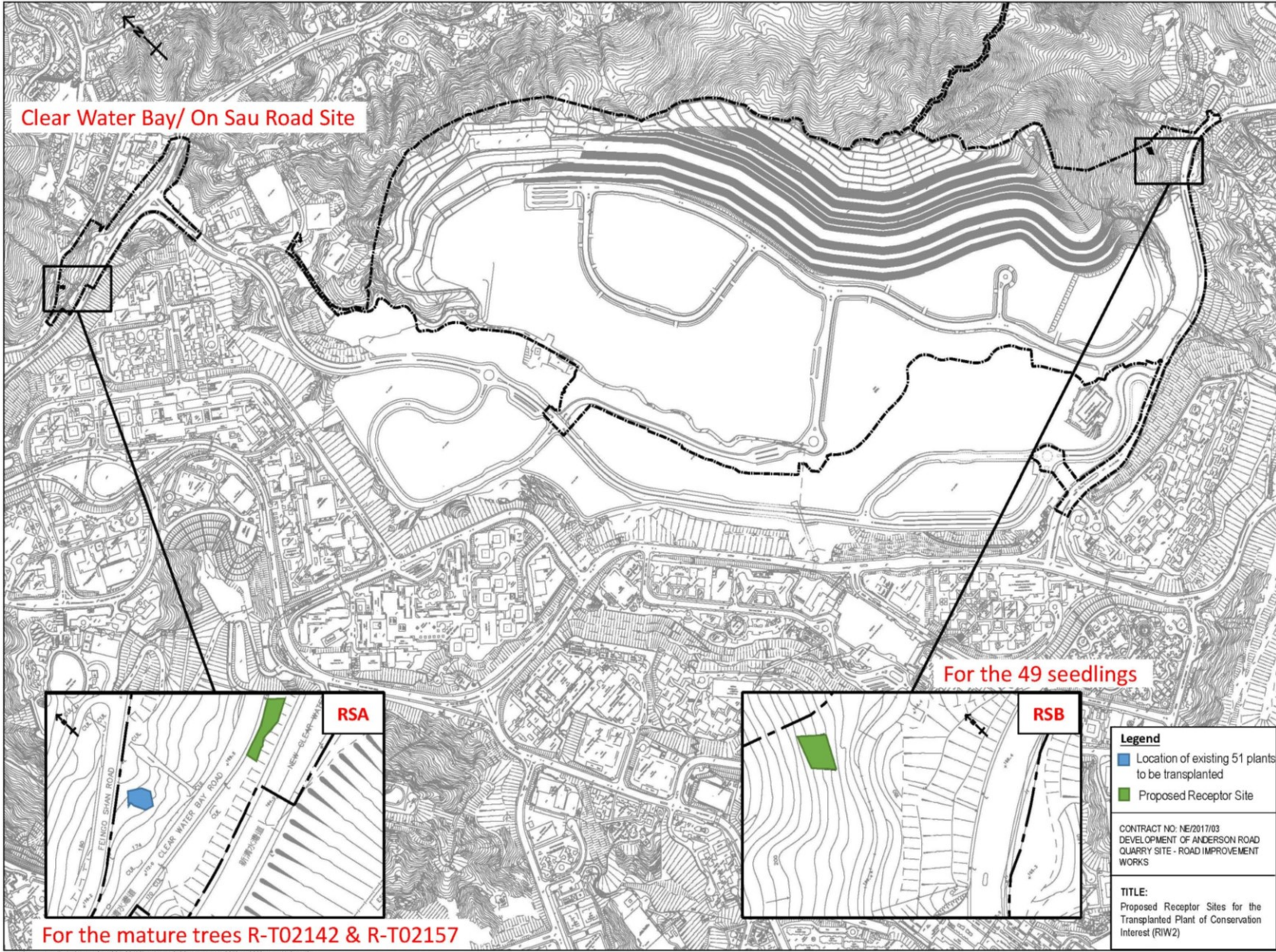
Any invasive plants such as *Bidens alba* (白花鬼針草), *Lantana camara* (馬纓丹), *Leucaena leucocephala* (銀合歡) and *Mikania micrantha* (薇甘菊) in the transplantation area or in close vicinity should be uprooted, packed and removed from the site.

Once pest and disease is detected, the Landscape Specialist Contractor should determine the application of chemical treatment, as well as the use of fertilizer during the maintenance period. Details and Contract requirements shall also follow GS Clause 3.34 and PS Clause 3.102.

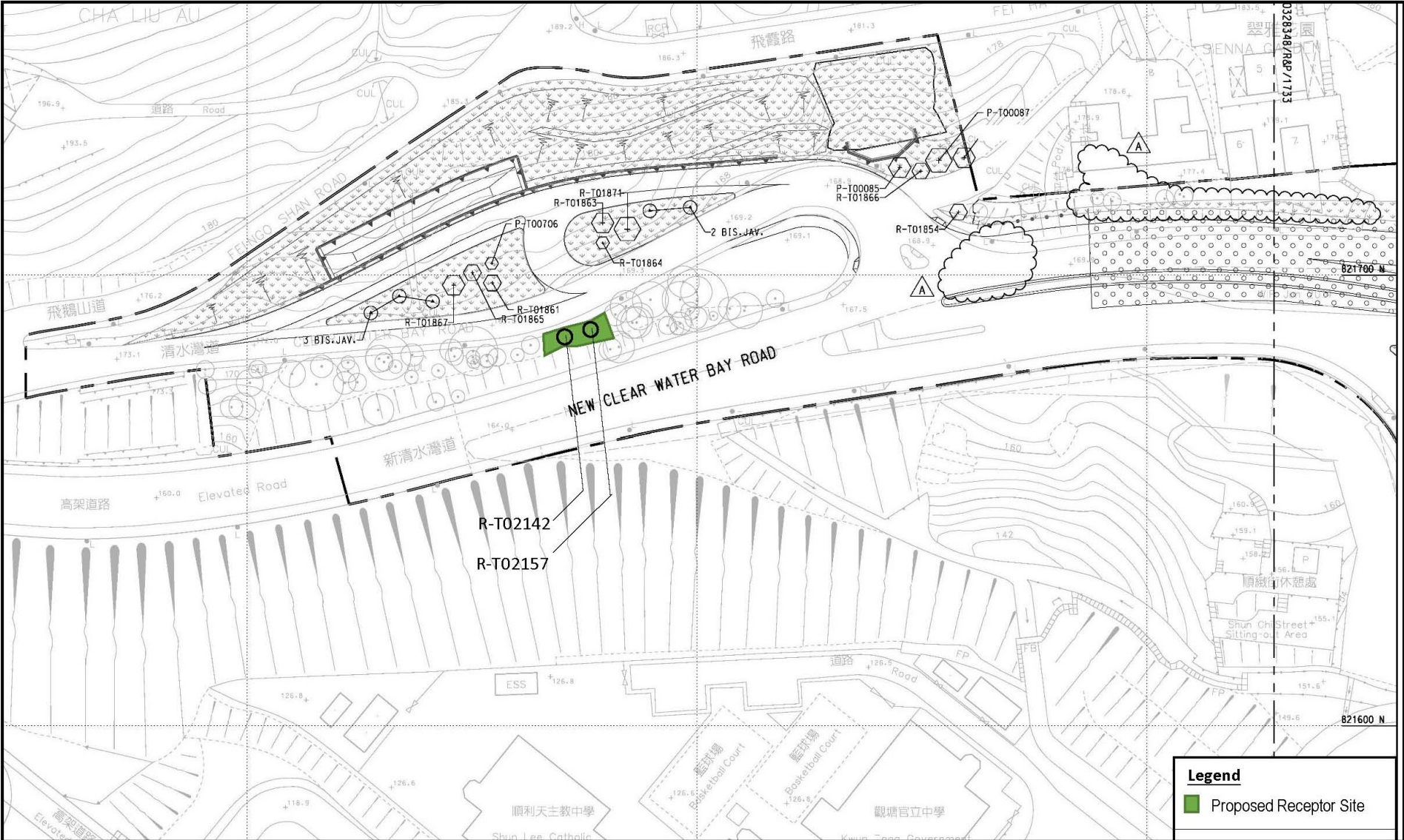
The Landscape Specialist Contractor shall submit a report of daily record of establishment works carried out on site during the three-year monitoring period on biweekly basis in the first three months and on a monthly basis for the remaining months.

During the three-year monitoring period, all 51 transplanted *Aquilaria sinensis* (土沉香) individuals should be monitored biweekly by Plant Specialist of the Environmental Team for the first three months and on a monthly basis for the remaining months. To ensure their condition throughout the establishment period, however, inspection frequency may be resumed to biweekly at any month as requested by the Plant Specialist and agreed by the Supervisor of the Contract based on each monitoring result. The Environmental Team should submit a monthly monitoring report to IEC, the Engineer and relevant Government Departments according to the Environmental Permit No. EP-513/2016.

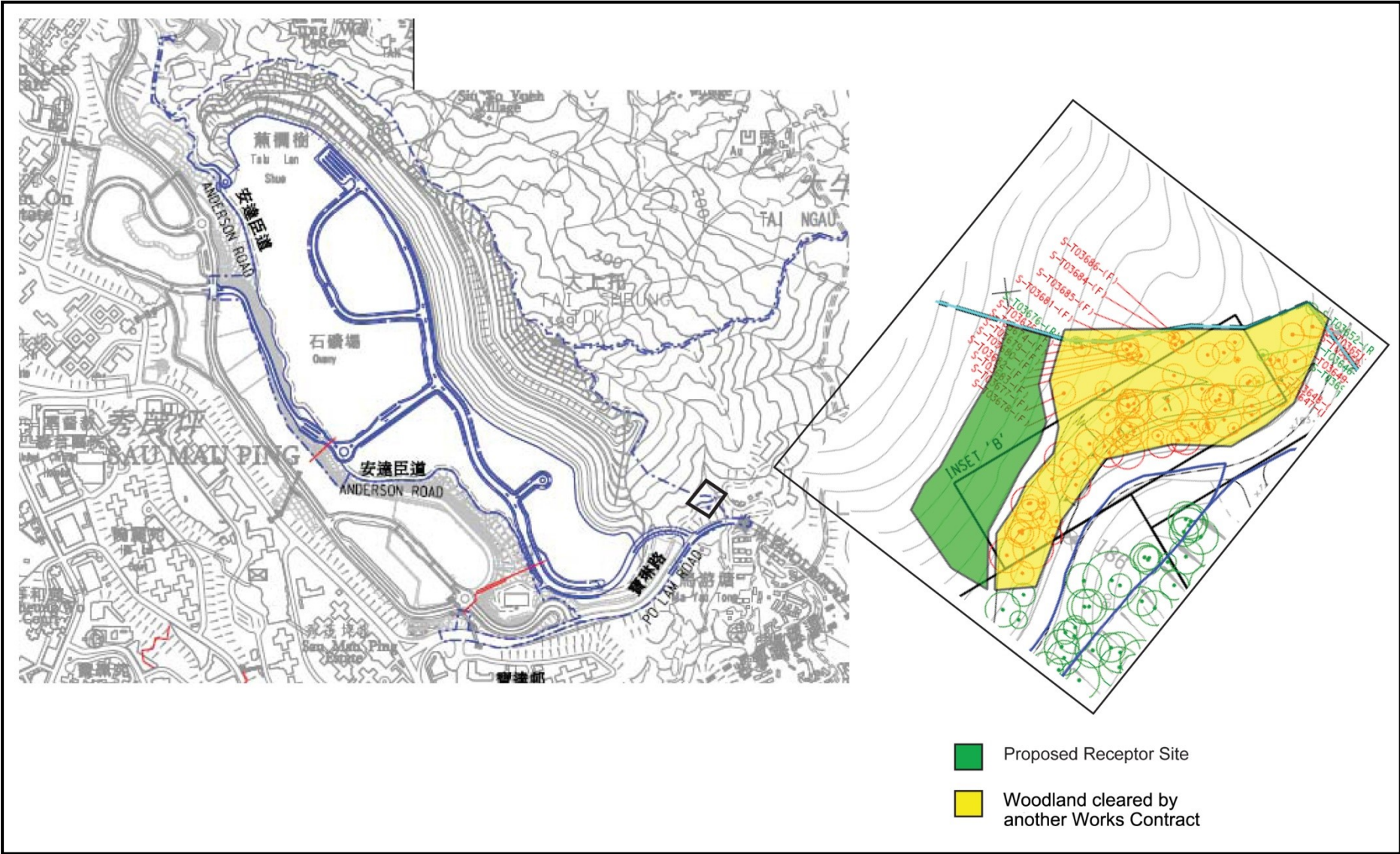
**Figure 1a.** Current location of the 51 plant individuals of conservation importance to be transplanted; and their proposed receptor sites at Clear Water Bay Road/ On Sau Road site (RSA) and near Po Lam Road (RSB) (Standardized drawings to be provided by the Supervisor of the Contract).



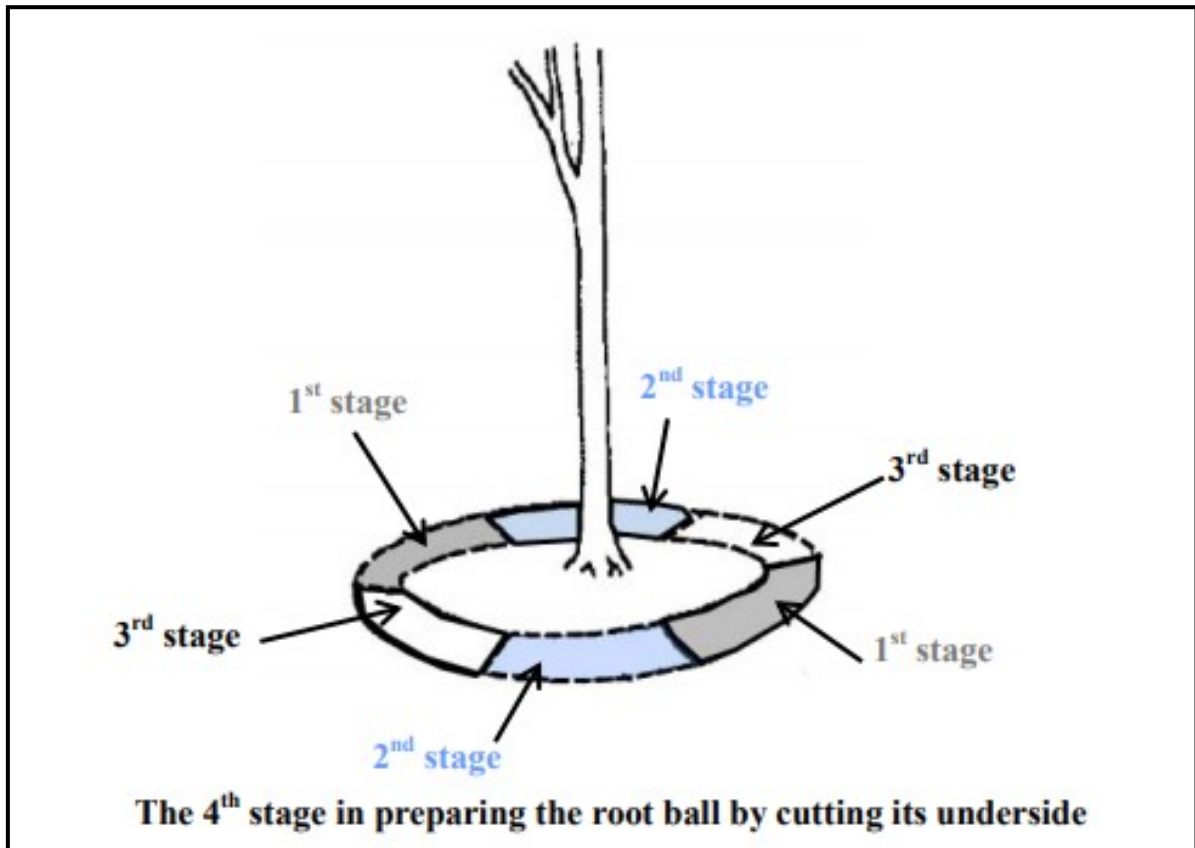
**Figure 1b.** Close up of proposed receptor site (RSA) for the mature tree R-T02142-(T) and R-T02157 at Clear Water Bay Road/ On Sau Road site. RSA is highlighted in green; the two trees enclosed by RSA are indicating their new location after transplantation. (Standardized drawings to be provided by the Supervisor of the Contract).



**Figure 1c.** Close up of proposed receptor site (RSB) for the 49 seedlings near Po Lam Road (RSB). (Standardized drawings to be provided by the Supervisor of the Contract).



**Figure 2.** Stage digging for transplantaion preparation of the mature trees R-T02142-(T) and R-T02157.



**Plate 1.** Site photos of receptor sites at Clear Water Bay Road/ On Sau Road site (RSA; top) and near Po Lam Road (RSB; middle and bottom).



**Table 1.** Individuals of plant species of conservation importance recommended for transplantation.

Species Name	Chinese Name	No.	Size	Height (m)	Crown spread (m)	DBH (mm)	Form	Health condition	Structural condition	Amenity value
<b>Original location before transplantation:</b> Clear Water Bay Road/ On Sau Road site										
<i>Aquilaria sinensis</i> <sup>1</sup>	土沉香	R-T02142-(T)	Tree	8	5	130	Fair	Fair	Fair	Good
		R-T02157-(F)	Tree	6	4	135	Fair	Fair	Fair	Fair
		A1	Seedling	0.43	0.5	N/A	Fair	Fair	Fair	Fair
		A2	Seedling	0.47	0.68	N/A	Fair	Fair	Fair	Fair
		A3	Seedling	0.55	0.6	N/A	Fair	Fair	Fair	Fair
		A4	Seedling	1.07	1	N/A	Fair	Fair	Fair	Fair
		A5	Seedling	0.95	0.62	N/A	Fair	Fair	Fair	Fair
		A6	Seedling	0.35	0.48	N/A	Fair	Fair	Fair	Fair
		A7	Seedling	0.75	0.74	N/A	Fair	Fair	Fair	Fair
		A8	Seedling	0.5	0.43	N/A	Fair	Fair	Fair	Fair
		A9	Seedling	0.7	0.8	N/A	Fair	Fair	Fair	Fair
		A10	Seedling	0.37	0.32	N/A	Fair	Fair	Fair	Fair
		A11	Seedling	0.5	0.55	N/A	Fair	Fair	Fair	Fair
		A12	Seedling	0.32	0.28	N/A	Fair	Fair	Fair	Fair
		A13	Seedling	0.29	0.27	N/A	Fair	Fair	Fair	Fair
		A14	Seedling	0.72	0.48	N/A	Fair	Fair	Fair	Fair
		A15	Seedling	0.48	0.44	N/A	Fair	Fair	Fair	Fair
		A16	Seedling	0.49	0.41	N/A	Fair	Fair	Fair	Fair
		A17	Seedling	0.53	0.5	N/A	Fair	Fair	Fair	Fair
		A18	Seedling	0.65	0.47	N/A	Fair	Fair	Fair	Fair
		A19	Seedling	0.32	0.39	N/A	Fair	Fair	Fair	Fair
		A20	Seedling	0.3	0.25	N/A	Fair	Fair	Fair	Fair
		A21	Seedling	0.43	0.55	N/A	Fair	Fair	Fair	Fair
		A22	Seedling	0.5	0.4	N/A	Fair	Fair	Fair	Fair
		A23	Seedling	0.9	0.83	N/A	Fair	Fair	Fair	Fair
		A24	Seedling	0.31	0.22	N/A	Fair	Fair	Fair	Fair
		A25	Seedling	0.34	0.32	N/A	Fair	Fair	Fair	Fair
		A26	Seedling	0.41	0.22	N/A	Fair	Fair	Fair	Fair
		A27	Seedling	0.46	0.53	N/A	Fair	Fair	Fair	Fair
		A28	Seedling	0.4	0.32	N/A	Fair	Fair	Fair	Fair
		A29	Seedling	0.56	0.28	N/A	Fair	Fair	Fair	Fair
		A30	Seedling	0.51	0.34	N/A	Fair	Fair	Fair	Fair
		A31	Seedling	0.44	0.3	N/A	Fair	Fair	Fair	Fair
		A32	Seedling	0.33	0.27	N/A	Fair	Fair	Fair	Fair
		A37	Seedling	0.26	0.41	N/A	Fair	Fair	Fair	Fair
		A38	Seedling	0.36	0.29	N/A	Fair	Fair	Fair	Fair



**Table 1 (cont'd).** Individuals of plant species of conservation importance recommended for transplantation.

Species Name	Chinese Name	No.	Size	Height (m)	Crown spread (m)	DBH (mm)	Form	Health condition	Structural condition	Amenity value
<b>Original location before transplantation:</b> Clear Water Bay Road/ On Sau Road site										
<i>Aquilaria sinensis</i> <sup>1</sup>	土沉香	A39	Seedling	0.35	0.32	N/A	Fair	Fair	Fair	Fair
		A40	Seedling	0.17	0.15	N/A	Fair	Fair	Fair	Fair
		A41	Seedling	0.25	0.2	N/A	Fair	Fair	Fair	Fair
		A42	Seedling	0.34	0.34	N/A	Fair	Fair	Fair	Fair
		A43	Seedling	0.3	0.27	N/A	Fair	Fair	Fair	Fair
		A44	Seedling	0.27	0.2	N/A	Fair	Fair	Fair	Fair
		A45	Seedling	0.29	0.25	N/A	Fair	Fair	Fair	Fair
		A46	Seedling	0.31	0.43	N/A	Fair	Fair	Fair	Fair
		A47	Seedling	0.23	0.17	N/A	Fair	Fair	Fair	Fair
		A48	Seedling	0.14	0.15	N/A	Fair	Fair	Fair	Fair
		A49	Seedling	0.3	0.26	N/A	Fair	Fair	Fair	Fair
		A50	Seedling	0.34	0.35	N/A	Fair	Fair	Fair	Fair
		A51	Seedling	0.24	0.29	N/A	Fair	Fair	Fair	Fair
		A52	Seedling	0.36	0.28	N/A	Fair	Fair	Fair	Fair
A53	Seedling	0.35	0.29	N/A	Fair	Fair	Fair	Fair		

Note and Conservation Status:

DBH are not measured for seedlings

1. Cap.586; AFCD (2003); VU in IUCN; NT in China; Cat. II; CPRDB

## **APPENDIX A**

- Contract Particular Specification (PS) Section 3 –  
Landscape Softworks and Establishment Works
- PS APPENDIX 3.1
- Contract drawing No. 60328348/R&P/1951

### SECTION 3

#### LANDSCAPE SOFTWORKS AND ESTABLISHMENT WORKS

##### GENERAL

G.S. Clause 3.06 is deleted and replaced by :-

- |                                      |      |  |
|--------------------------------------|------|--|
| <i>Weather and ground conditions</i> | 3.06 | (1) Planting shall take place in suitable weather conditions. Planting shall not take place in weather conditions which will result in initial drying out of root systems and/or scorching of leaves. Ideally planting shall take place in overcast or moist conditions. If planting has to be carried out in sun or drying winds or in hot and dry weather, plants awaiting planting shall at all times be covered to prevent drying out. |
|                                      |      | (2) The <i>Contractor</i> shall cease planting immediately when in the opinion of the <i>Project Manager</i> the weather conditions or ground conditions adversely affect the planting works.  |

##### GLOSSARY OF TERMS

The following is added after G.S. Clause 3.10 :-

- |                             |       |   |
|-----------------------------|-------|---|
| <i>Establishment period</i> | 3.10A | Establishment Period is defined as the period specified in this contract for the Establishment Works are performed. |
|-----------------------------|-------|---|

##### MATERIALS

G.S. Clause 3.17(c) and (d) are deleted and replaced by :-

- |                     |      |   |
|---------------------|------|---|
| <i>Small shrubs</i> | 3.17 | (c) A height above soil level between 150mm and 400mm,                                    |
|                     |      | (d) Grown and supplied in a container not less than 125mm in diameter and 150mm deep, and |

The following is added after G.S. Clause 3.17 :-

- |                      |       |  |
|----------------------|-------|--|
| <i>Medium shrubs</i> | 3.17A | Medium Shrubs shall have the following characteristics :   |
|                      |       | (a) A seeding or rooted cutting two or more years old which has a bushy habit, bushiness which has been encouraged by pruning, |
|                      |       | (b) Well furnished with shoots to produce a plant with a diameter two-thirds of the height,                                    |
|                      |       | (c) A height above soil level between 400mm and 700mm,   |
|                      |       | (d) Grown and supplied in a container not less than 175mm in diameter and 200mm deep, and                                      |

- (e) Free of pests, fungi and disease.

G.S. Clause 3.18(c) and (d) are deleted and replaced by :-

- |                     |      |   |
|---------------------|------|---|
| <i>Large shrubs</i> | 3.18 | (c) A height above soil level between 700mm and 1000mm,                                   |
|                     |      | (d) Grown and supplied in a container not less than 175mm in diameter and 200mm deep, and |

The following is added after G.S. Clause 3.29 :-

- |                         |       |   |
|-------------------------|-------|---|
| <i>Origin of plants</i> | 3.29A | The <i>Contractor</i> shall state the origin of all trees, shrubs, turves, sprigs and plant material, in good time before planting. The <i>Project Manager</i> may inspect the nursery and agree on a selection of all plant material for Acceptance. All plant material subsequently delivered to the Site shall be to at least the same standard in all respects as that accepted. The <i>Contractor</i> shall note that in order to provide all the plant material as specified it may be necessary for him to grow the material in his own nursery in advance of commencing planting works on Site. |
|-------------------------|-------|---|

- |                                       |       |   |
|---------------------------------------|-------|---|
| <i>Substitution of plant material</i> | 3.29B | (1) In the event of plant material as specified herein not being available, the <i>Contractor</i> shall notify the <i>Project Manager</i> at the beginning of this contract in order that suitable substitutes can be considered. The <i>Contractor</i> shall propose substitutes which are similar in height, shape, flowering characteristics and function as the original species. |
|---------------------------------------|-------|---|

(2) The *Contractor* shall have photographs taken of accepted samples for each species and plant size to be used. The photographs shall be used as a standard to which similar species to be supplied and planted in this contract shall be equivalent.

(3) Any changes, such as planting densities, necessitated by the need for substituting species shall be at no extra cost to this contract.

(4) No substitute shall be made without the prior written acceptance of the *Project Manager*.

(5) No substitution will be permitted within 12 months prior to the actual time of planting.

- |                                     |       |   |
|-------------------------------------|-------|---|
| <i>Materials to be as specified</i> | 3.29C | All plant material shall be true to species and healthy and shall not be less than the minimum sizes specified. Plants having any habit or growth other than that specified shall be considered unacceptable. |
|-------------------------------------|-------|---|

The following is added after G.S. Clause 3.30(2) :-

- Soil-mix*                      3.30
- (3)        Soil-mix delivered and installed on site shall be tested for nitrogen, phosphorus and potassium (N.P.K.) value, organic matter content, cation exchange capacity ratio, organic carbon, pH value, physical content of sand, silt and clay, and water content. Soil testing shall be arranged by the *Contractor* and shall be conducted in the laboratory accredited by Hong Kong Laboratory Accreditation Scheme (HOKLAS) or equivalent accepted or institute at the *Contractor's* own source, and the report shall be submitted to the *Project Manager* for Acceptance.
- (4)        If the results of the test show that the soil-mix does not meet the nutrient and organic status required for soil-mix, then the *Contractor* shall make good the soil-mix by bringing it to the nutrient and organic status specified. The *Contractor* shall obtain Acceptance for his proposed remedial measures from the *Project Manager* for Acceptance before undertaking any work.
- (5)        The top-soil mix shall be free from grass or weed growth of any kind, sticky clay, salt, sharp grit and stones larger than 1mm in any diameter and sub-soil should be clean, friable decomposed granite, free from grass or weed growth, other foreign matters and stones over 25mm in diameter found in soil-mix are not accepted. The *Contractor* shall supply a representative 2 kg sample of accepted soil-mix to the *Project Manager* with a certificate indicating the source for the Acceptance of the *Project Manager*. Acceptance to the sample must be obtained before bulk delivery commences, and Acceptance of the sample will not preclude the right of the *Project Manager* to reject any imported material which in the opinion of the *Project Manager* falls appreciably below the standard of the sample. The sample shall be retained by the *Project Manager* in a location on Site which will allow inspection and comparison throughout the period of this contract.
- (6)        The *Contractor* shall ensure that soil-mix heaps are properly maintained and that soil-mix shall be placed in its final position within 12 months of importation to Site or, for site strip material, deposition for storage on Site. Weed control shall be carried out by spraying with accepted weedkiller.
- (7)        If the period between the analysis of the soil-mix as above and the commencement of any deposition of soil-mix exceeds 12 months then the *Contractor* shall carry out a second analysis of the soil-mix. If this second analysis shows that the soil-mix has deteriorated in the nutritional requirements for soil-mix the *Contractor* shall make good the soil-mix by bringing it to the nutrient and organic status specified.

(8) The *Contractor* shall give the *Project Manager* four weeks notice of his intention to commence deposition of soiling operations in order to allow for the results of the analysis to be available before the commencement of soiling.

(9) No change in the source of soil-mix shall be allowed without the prior Acceptance of the *Project Manager* based on such tests and samples as specified herein.

(10) The *Contractor* shall prepare soil-mix on site. Mixing shall not take place during periods of heavy rain, nor when the soil is saturated. Mixing operations shall cease if the moisture content of the completely decomposed granite is too high to achieve thorough mixing with the soil conditioner.

G.S. Clause 3.31(1) is deleted and replaced by :-

*Soil conditioner*      3.31(A)      (1) Soil conditioner shall be properly composted organic material. However the organic matter shall be free from impurity and containing no substance injurious to plants. It shall have all of the following properties

- (a) pH between 5.0 and 7.5
- (b) moisture content of 30% - 50%
- (c) fine in texture
- (d) consistency of free flowing capacity
- (e) a carbon/ nitrogen ratio of between 25-70
- (f) Organic matter content not less than 85% (dry matter)

(2) When a composted organic material is used it shall be stable and not liable to decompose further generating heat. The *Contractor* shall produce a certificate of analysis stating composition and physical and chemical characteristics. The analysis shall be carried out by a laboratory accepted by the *Project Manager*.

(3) A sample of 1.0 kilogram shall be submitted to the *Project Manager* for Acceptance before importation and use.

G.S. Clause 3.32 is deleted and replaced by :-

*Mulch*      3.32      (1) Mulch shall be a mixture of shredded bark and wood chips. The mulch shall be free from impurities and be heavy enough to prevent dispersal by wind. It shall contain material with a particle volume greater than 500 mm<sup>3</sup> consisting at least 50% by volume of the mix.

- (a) Wood chips (as opposed to bark) shall not exceed 50 mm particle size in any dimensions.
- (b) Any wood content shall be inert and free of resinous toxins. The pH of the mulch shall be not less than 6.0.

(2) The *Project Manager* for shall be invited to inspect production techniques and the suppliers' facilities, prior to any Acceptance.

G.S Clause 3.34 (5) is deleted and replaced by :-

*Fertilizer* 3.34 (5) Chemical fertilizers shall be stored in waterproof sealed bags under shelter away from water and direct sunlight.

The following is added after G.S. Clause 3.34(5) :-

- (6) Pre-planting fertilizer shall be in the form of tablet.

The following is added after G.S. Clause 3.37 :-

*Root activator* 3.37A Root activator shall be a chemical which contains plant hormones gibberellins (G.A.), and indole-3-acetic acid (IAA), and which can activate root growth such as 'Rootone' or equivalent and accepted.

*Sack, bags, containers, etc.* 3.37B The *Contractor* shall retain for inspection by the *Project Manager* for all sacks, bags, containers and the like in which fertiliser, mulch, grass-seed, pesticides, herbicides and the like are supplied and shall not dispose of these without the consent of the *Project Manager*.

*Temporary protective fencing for newly planted areas* 3.37C Temporary protective fencing shall be at least 1.5m tall comprising end straining posts with struts, intermediate posts with galvanized line wire, galvanized twisted wire and accepted split bamboo pales.

(1) Straining posts shall be installed at corners, ends of runs and at intermediate positions 30 metres apart maximum. Posts shall be 1000mm long by 80mm diameter or 80mm square. Struts shall be 1000mm long by 80mm diameter or 80mm square and shall be housed and securely nailed to all straining posts in the direction of each line of fencing.

(2) Intermediate posts shall be installed at 2.5 metres apart maximum and shall be 1800mm long by 100mm diameter or 100mm square.

(3) All posts and struts shall be of accepted timber treated with accepted preservative and shall be driven into the ground for a depth of 600mm minimum.

(4) Two strands of 3.15mm high tensile galvanised steel wire to BS 4102 shall be strained and stapled with 38 x 4mm galvanised staples and fixed 150mm from top of post and 150mm above ground level. Each line wire shall be strained tightly by means of a ratchet strainer. All line wires shall be secured to intermediate posts by one staple driven to a running fit and to straining posts by two complete turns round the post with the wire twisted back on itself and staples driven tightly into the post.

(5) Pales shall be hand-driven from bamboo poles approximately 30mm diameter. Pales shall be straight, pointed at the top as shown and notched 80mm from top and bottom.

(6) The wire for wiring shall be not less than 2mm diameter galvanised mild steel wire conforming to BS 4102. Each line of wiring shall consist of two wires twisted together between the pales.

(7) Pales to be positioned with no more than 50mm spacing between pales. One line of wire shall be fixed 80mm from the top of the pales, one in the middle and one 80mm from the bottom. Every 500mm top and bottom strained wires shall be bound to twisted wires on bamboo paling by means of wire twists of 2mm gauge galvanised wire.

*Plant name* 3.37D On planting plans, where botanical names and Chinese characters are given for plants; the botanical name shall always take precedence.

*Notices and instructions* 3.37E (1) In respect to landscape works, the *Contractor* shall give forty-eight hours' notice to the *Project Manager*, of his intention to commence any one of the following operations: soiling, setting out, planting, hydroseeding, fertilising, and visits to carry out establishment works.

(2) The *Contractor* shall undertake any remedial landscape works within twenty-four hours of notice by the *Project Manager*.

*Cable wire system* 3.37F (1) All work shall comply with the requirement of this contract/ tender documents to design, supply and install of the wire green wall system as shown on drawings or accepted shop drawings submitted by *Contractor*.

(2) The system shall be a proprietary consists of grade 316 stainless steel wires, eyebolts, anchor bolts and other accessories.

(3) The proprietary system shall provide at least 2 years functional warranty.

(4) Prior to installation, the *Contractor* shall submit Method Statements and Shop drawings for the installation.



*Drainage aggregate* 3.37G Aggregate shall be:

- (a) Clean, rounded stone, 10-20 mm diameter, and
- (b) Free from weeds, other building materials, foreign matter and contamination.

Drainage aggregates, if so instructed by the SO, shall be subjected to sieve analyses to BS EN 933-1.

*Geotextile* 3.37H

Filter layer shall be a permeable non-woven, thermally bonded geotextile filter fabric, which is not affected by acids, alkalis, bacteria, humidity, or rotting, and shall meet performance requirements set out as below or any accepted by *Project Manager* in sound performance for minimum 12 years:

Type	Properties	Test Method	Acceptance Standards (±10%)
<b>A</b>	Mechanical Properties (i) Wide width strip tensile - Mean peak strength - Elongation at peak strength (ii) CBR puncture resistance - Mean peak strength	<b>BS EN ISO 10319</b>	3.0 kN/m 35 %
		<b>BS EN ISO 12236</b>	1.3 kN/m 525 N
	Hydraulic Properties (i) Pore size - Mean AOS O <sub>90</sub> (ii) Permeability - 5cm head	<b>BS EN ISO 12956</b>	300 µm
		<b>BS EN ISO 11058</b>	150 l/m <sup>2</sup> /s
<b>B</b>	Mechanical Properties (i) Wide width strip tensile - Mean peak strength - Elongation at peak strength (ii) CBR puncture resistance - Mean peak strength	<b>BS EN ISO 10319</b>	6.0 kN/m 25 %
		<b>BS EN ISO 12236</b>	2.6 kN/m 1050 N
	Hydraulic Properties (i) Pore size - Mean AOS O <sub>90</sub> (ii) Permeability - 5cm head	<b>BS EN ISO 12956</b>	180 µm
		<b>BS EN ISO 11058</b>	130 l/m <sup>2</sup> /s
<b>C</b>	Mechanical Properties (i) Wide width strip tensile - Mean peak strength - Elongation at peak strength (ii) CBR puncture resistance - Mean peak strength	<b>BS EN ISO 10319</b>	8.0 kN/m 28 %
		<b>BS EN ISO 12236</b>	3.4 kN/m 1500 N
	Hydraulic Properties (i) Pore size - Mean AOS O <sub>90</sub> (ii) Permeability - 5cm head	<b>BS EN ISO 12956</b>	150 µm
		<b>BS EN ISO 11058</b>	100 l/m <sup>2</sup> /s

*Drainage layer*            3.371        Drainage layer shall be high-performance CE-marked with an dimple design made out of recycled polystyrene or accepted equivalent drainage system having the same function with a layer of filter layer and a durable supportive layer for draining infiltrated water and capable to withstand a load required under the Fire Services Department. Drainage layer is high compressive strength and a construction height of approx. 12.5 mm. A non-woven geotextile is bonded to each dimple as a filter layer. The drainage layer should fulfill the requirement as shown below:

Properties

- Material dimpled sheet: recycled high impact polystyrene (HIPS)
- Material geotextile filter: polypropylene (PP) and polyethylene (PE)
- Material pressure-dividing slip film: polypropylene (PP) – ND 220 only
- Construction height: approx. 12.5 mm
- Compressive strength: approx. 700 kPa
- Weight: approx. 908 g/m<sup>2</sup>
- Drainage capacity at  $i = 1$  at 20 kPa: approx. 5.17 l/(s.m)
- Drainage capacity at fall ratio 2 % at 20 kPa: approx. 0.52 l/(s.m)

**SUBMISSIONS**

*Samples of materials*            3.40        G.S. Clause 3.40(1) is replaced by :-

(1)        (a)    A sample of geotextile

            (b)    A sample of drainage layer

            (c)    A sample of drainage aggregate

            (d)    A set of cable wire system, e.g. eye bolt, wire and any materials included

            (e)    Shop drawing of cable wire system

G.S. Clause 3.40(2) is deleted and replaced by :-

- (2) (a) Samples of each species of plant material to be planted on Site shall be made available at a nursery in Hong Kong for inspection and acceptance by the *Project Manager* prior to delivery on Site.
- (b) Any plant material which does not conform to specification or the accepted standard shall be rejected by the *Project Manager*, and will be replaced by the *Contractor* with appropriate standard of material.

#### **HANDLING, STORAGE AND TRANSPORT**

The following is added after G.S. Clause 3.44(2) :-

- Storage of plants*      3.44      (3)      The *Contractor* shall seek the written Acceptance of the *Project Manager* on the storage of plants, method, equipment and storage facilities on Site.

G.S. Clause 3.45 is deleted and replaced by :-

- Storage of trees and shrubs*      3.45      (1)      Trees and shrubs which are not immediately planted in their permanent positions shall be supported upright on level ground, regularly watered and maintained in good condition.
- (2)      Any bare-rooted plant material shall be heeled into the ground with all the roots covered by soil-mix.

The following is added after G.S. Clause 3.48 :

- Samples and tests*      3.48A      (1)      The *Project Manager*, may at any time, takes and analyze samples of materials to verify conformity with Specifications. The *Contractor* shall furnish samples upon request by the *Project Manager*.
- (2)      Rejected materials shall - immediately be removed from Site
- (3)      Cost of testing of materials not meeting the Specification shall be borne by the *Contractor*.

### PRE-PLANTING WORKS

G.S. Clause 3.53 is deleted and replaced by :-

- |                |      |  |
|----------------|------|--|
| <i>Soiling</i> | 3.53 | <p>(1) Soil-mix shall be spread and levelled in raised planter beds to a depth of min. 1200mm for trees and 600mm for shrubs and ground covers.</p> <p>(2) Existing soil of pits for seedling trees, whip trees, climbers, groundcovers, herbaceous and shrub planting (other than in raised planter beds) shall be excavated from the pits and each pit shall be mixed with 4 litres of soil conditioner, then backfilled into the pit with 50g of pre-planting fertilizer tablet prior to planting.</p> <p>(3) Placing and spreading of soil shall not take place during periods of heavy rains, nor when the soil-mix is saturated. When, in the opinion of the <i>Project Manager</i>, conditions are unsuitable for placing and spreading of soil, operations shall cease and shall only be resumed when authorised by the <i>Project Manager</i>. After soiling, areas are to be protected from further compaction and trafficking.</p> <p>(4) The <i>Contractor</i> shall be responsible for ensuring that the soil-mix maintains its specified quality between the time after deposition and the planting operations.</p> <p>(5) Excess soil generated from planting pits and not used as backfill, water basins, or in establishing final grades shall be removed by the <i>Contractor</i> from site.</p> |
|----------------|------|--|

The following is added after G.S. Clause 3.53 :-

- |                           |       |  |
|---------------------------|-------|--|
| <i>Control of erosion</i> | 3.53A | <p>The <i>Contractor</i> shall take all necessary preventative measures to control erosion and siltation. The <i>Contractor</i> shall restore or replace any portion of the Site, including those which have been both the subject of a certificate of Completion of a <i>section</i> or a part of the <i>works</i> and on which broadcast seed or hydroseeding is required to be carried out, which erodes, silts up or is otherwise damaged.</p> |
|---------------------------|-------|--|

### PLANTING

The following is added after G.S. Clause 3.58 :-

- |                    |       |   |
|--------------------|-------|---|
| <i>Setting out</i> | 3.58A | <p>(1) The <i>Contractor</i> shall be responsible for accurately setting out according to the Drawings all areas to be planted to the acceptance of the <i>Project Manager</i> prior to the commencement of planting, and shall rectify errors in setting out. Any discrepancy in Site area between that shown on the plans and the actual area on the ground shall be notified to the <i>Project Manager</i> as soon as it is discovered and prior to commencement of any relevant operations.</p> |
|--------------------|-------|---|

(2) Tree and shrub areas shall be marked in outline with pegs, spaced not less than 15 m apart. The pegs shall be not less than 750 mm long and 50 mm in thickness and shall be firmly driven into the ground. The top 300 mm of each peg shall be painted white.

(3) The *Contractor* shall mark out the required planting interval with canes, stones, chalk or other suitable markers along the longest edge of the area to be planted.

(4) The first row of plants shall be the required distance from this edge and directly in line with each marker. In the case of planting areas edged by kerbs or walls, adequate planting space should be allowed between the edge/foundations and the first row of plants. In the case of planting areas adjacent to other planting areas, the first row of plants shall be planted at a distance which is half the specified planting distance for that species from the edge.

(5) The second row shall be the required distance from the first. The pattern will be repeated over the whole planting area.

(6) In the case of woodland mix and shrub mix planting, the plants shall be planted in positions indicated on the Drawings. Sufficient clearance (1m radius) around existing trees should be provided.

(7) The approximate numbers of plants to be planted per half day shall be set out by laying them down beside the hole in which they are to be planted. Plants shall not be removed from their containers until planting is taking place. All setting out shall be to the acceptance of the *Project Manager*.

(8) During the setting out of the planting, the *Contractor* shall notify the *Project Manager* of the position of any tree or group of trees which occur within the following tolerance:

- (a) trees to be planted at least 1.5m from road kerb/ edge
- (b) large shrubs to be planted within 1.0m of the road edge.
- (c) medium shrubs to be planted within 0.6m of the road edge
- (d) small shrubs to be planted within 0.3m of the road edge.

The above dimensions do not apply where crash barriers are provided between the planting and the carriageway or where planting is located within a raised planting bed.

The *Contractor* shall notify the *Project Manager* of any of the above situations prior to carrying out any relevant works in those areas.

The following is added after G.S. Clause 3.60(3) :-

*Planting* 3.60 (4) Tree flares cannot be covered by any material, e.g. soil or mulching. Soil or mulching should be removed once tree flares are being covered during maintenance.

G.S. Clause 3.62 is deleted and replaced by :-

*Mulching* 3.62 (1) After planting and watering, mulch shall be spread to a consolidated thickness of at least 50 mm in planters and all planted areas not previously hydroseeded. Finish level of mulch shall be 25mm below adjacent finished surfaces.

(2) Mulch shall be dished around the base of the plants. The *Contractor* shall take care not to damage the plant material during mulching operations. Mulch shall be applied after planting and watering have taken place.

The following is added after G.S. Clause 3.64(3) :-

*Pit planting of seedlings, shrubs, whips, climbers, ground covers and herbaceous plants* 3.64 (4) Whip planting shall be carried out in areas which have been hydroseeded as part of this contract. The *Contractor* shall allow in his programming of planting works sufficient time for the hydroseeding to establish and provide 90% cover to the acceptance of the *Project Manager* before whip and shrub mix planting operations commence. Grass shall be mown to 50mm before pit planting commences.

The following is added after G.S. Clause 3.68 :-

*Watering* 3.68A Immediately after planting, all plants shall be thoroughly watered with fresh water such that the roots of the plants are soaked.

*Bamboo/Plastic fencing to planted areas* 3.68B (1) Protective fencing shall be erected where newly planted areas are adjacent to public footpaths and as indicated on the Drawings.

(2) Protective bamboo/plastic lattice fencing shall be 1200mm high and consist of a bamboo/plastic lattice and frame of approximately 25mm bamboos, lashed to 25mm x 25mm x 4mm thick mild steel angle posts, and approximately 50mm bamboo top rail; the bamboo to be placed on the footpath side of the posts. The *Contractor* shall submit drawing for the *Project Manager's* acceptance prior to erection.

*Planting through erosion control mat with and without wire mesh* 3.68C (1) In areas where erosion control mat (and wire mesh) has been laid, the *Contractor* shall prepare trial panels demonstrating the technique for pit planting through the erosion control mat (and wire mesh) (panel size min. 4 m x 4 m / 9 no. pits) in-situ, as instructed by the *Project Manager*. Acceptance of the sample should be obtained from the *Project Manager* prior to commencement of planting through erosion control mat (and wire mesh) generally.

(2) The *Contractor* shall comply with the following in pit planting through erosion control mat (and wire mesh):

- (a) Erosion control mat (and wire mesh) shall be cut in 'T' shape and flaps folded back to allow pit to be excavated. Complete holes shall not be cut in the erosion control mat.
- (b) Plants shall be planted at correct level with respect to surrounding slope face and heeled in to create slight depression in slope around plant.
- (c) Only flaps of the erosion control mat (excluding wire mesh) shall be folded back into original position after pit planting and secured with 200 mm long aluminium U-pin as specified in PS Clause 3.37F.

### ESTABLISHMENT WORKS

The clause 3.79(1) is deleted and replaced by :-

*Establishment works*

3.79

(1) Except for the planting works of woodland compensation, the *Contractor* shall be required to maintain the planting works of all planted areas for a period of 365 days as specified after the date certified by the *Project Manager* and recognised by taking-over maintenance department that the landscape works have been satisfactorily completed and in that time the *Contractor* shall be required to carry out establishment works whether or not instructed by the *Project Manager*.

The following is added after G.S. Clause 3.79(3) :-

(4) The *Contractor* shall report to the *Project Manager* before and after carrying out any establishment works. Reports shall be submitted in duplicate on forms provided by the *Contractor* and of a style accepted by the *Project Manager*.

(5) The *Contractor* shall submit a programme to the *Project Manager* for acceptance before the commencement of establishment works. The programme shall include all the items of operations as defined below. Other than the items of mulching, pruning and fertilising, the *Contractor* shall propose in the programme the number of operations for the other items to be carried out during the establishment period. Once the programme is accepted, the *Contractor* shall carry out all the operations unless subsequently instructed otherwise by the *Project Manager*.

(6) Where part of an existing planting area has been partially reinstated under this contract, the reinstated area shall be subject to establishment works as specified herein.

		(7) During the establishment period, tree risk assessment should be conducted by competent Certified Arborist at least at six-month intervals.
		G.S. Clause 3.83 is deleted and replaced by :-
<i>Firming up plants</i>	3.83	(1) Plants which become loose as a result of wind rock or other causes shall be firmed up.  (2) The <i>Contractor</i> shall inspect the Site regularly for this purpose and after each storm or typhoon, to assess damage, which shall be reported to the <i>Project Manager</i> . Any damaged branches shall be carefully pruned or as required by the <i>Project Manager</i> .  The following is added after G.S. Clause 3.84(1):-
<i>Watering</i>	3.84	(1A) Any inspection of watering requirements shall be made in dry weather by the <i>Contractor</i> and the <i>Project Manager</i> twice weekly or as required by the <i>Project Manager</i> .  The following is added after G.S. Clause 3.84(3) :-  (4) The <i>Contractor</i> shall complete watering operations within 24 hours of an inspection which deems watering to be necessary.  (5) When required, an analysis of water to be used shall be obtained by the <i>Contractor</i> for acceptance by the <i>Project Manager</i> .  The following is added after G.S Clause 3.85(3) :-
<i>Weeding</i>	3.85	(4) All areas within 300mm radius of the base of each planting shall be kept in a weed/grass free and tidy condition.  (5) The <i>Contractor</i> shall weed areas as necessary and shall complete weeding within seven days of inspection.  G.S. Clause 3.87 is deleted and replaced by :-
<i>Grass cutting</i>	3.87	(1) Grassed areas shall be cut by manual or mechanical methods agreed by the <i>Project Manager</i> and in a manner that does not cause pulling of roots or damage to planting in or near the grassed area. All cuttings shall be raked off and disposed of within 24 hours after cutting.  (2) Grass in all hydroseeded areas shall be reduced by cutting to a height of 100mm when it reaches 300m high. The <i>Contractor</i> shall cut as often as necessary to maintain the height in this range.  (3) Grass areas shall be weed free in accordance with G.S. Clause 3.81 before any grass cutting is carried out.



G.S. Clause 3.88 is deleted and replaced by :-

- |                          |      |  |
|--------------------------|------|--|
| <i>Litter collection</i> | 3.88 | (1) All litter exposed by grass cutting shall be gathered up and disposed of within 24 hours.  |
|                          |      | (2) All litter/rubbish in the planting areas shall be removed from the site. Litter/rubbish removal shall be completed within two days after inspection. |

The following is added after G.S. Clause 3.90 (2)(d) :-

- |  |      |   |
|--|------|---|
| <i>Control of pests, fungi and disease</i> | 3.90 | (2) (e) Use of all pesticides, insecticides, fungicides and chemicals are to be with care and to have due regard to the safety and convenience of the general public and be in accordance with the Hong Kong Government Environmental Guidelines. It shall be carefully controlled to avoid unnecessary dispersion. |
|--|------|---|

G.S. Clause 3.92 is deleted and replaced by :-

- |                 |      |  |
|-----------------|------|--|
| <i>Mulching</i> | 3.92 | (1) All mulch which is disturbed by replacement planting, weeding or watering shall be made good. Additional mulching over areas of forking over and over areas disturbed by others shall be carried out if instructed by the <i>Project Manager</i> .   |
|                 |      | (2) During the establishment period, the <i>Contractor</i> shall carry out two applications of mulch each to a thickness necessary to bring the total depth of mulch of 50 mm unless otherwise specified after the application. The final mulching operation is to be carried out in the last month of the establishment period. |

The following is added after G.S. Clause 3.92 :-

- |  |       |  |
|--|-------|--|
| <i>Removal of temporary protective fencing</i> | 3.92A | The <i>Contractor</i> shall remove the temporary protective fencing at the end of the establishment period unless otherwise directed by the <i>Project Manager</i> .   |
| <i>Insect and disease control</i>              | 3.92B | The <i>Contractor</i> shall report to the <i>Project Manager</i> any such occurrence and shall carry out remedial eradication by use of sprayed insecticide or fungicide, used in accordance with the manufacturer's instructions. Use of such sprays is to be with care and to have due regard to the safety and convenience of the general public and be in accordance with the Hong Kong Government Environmental Guidelines. It shall be carefully controlled to avoid unnecessary dispersion. |
| <i>Treatment on red imported fire ant</i>      | 3.92C | (1) The <i>Contractor</i> shall inspect the plants for Red Imported Fire Ants (RIFA) before they are planted on site and inspect the planted areas regularly.  |

(2) The *Contractor* shall maintain and protect all the existing planting from invasion of RIFA. Whenever such maintenance or protection is not possible, the *Contractor* shall report to the *Project Manager* with alternative proposal and resume the original condition

(3) The *Contractor* shall report immediately to the *Project Manager* upon discovery of mound(s) of suspected RIFA and employ a pest control specialist as specified in the latest list of “Pest Control Companies in the control of Red Imported Fire Ant” issued by Agriculture, Fisheries and Conservation Department (“AFCD”) to provide treatment services for the RIFA including their mound(s).

(4) The treatment services shall include collection services of the suspected RIFA; controlling service against confirmed RIFA; and surveillance monitoring on the RIFA as stated in the technical note – Red Imported Fire Ant Control Methods, issued by AFCD on 15/5/2008.

### TREE TRANSPLANTING

G.S. Clause 3.97 (2) & 3.97 (7) are deleted and replaced by :-

*Transplanting of  
existing trees*      3.97

(2) Before the commencement of any work to the trees on the Site, the *Contractor* shall inspect all the trees to be transplanted and prepare the detailed method statement and works programme for the transplanting works with the incorporation of the expert advice from the independent tree specialist (ITS). The ITS shall have qualification or certification offered by a professional institution or industry organisation on arboriculture after successful completion of examination or assessment process conducted within or accredited by the institution or organisation such as Certified Arborist of the International Society of Arboriculture, Professional Member or Fellow of the Arboricultural Association of the UK, Accredited Arboricultural Practitioners of the Hong Kong Institute of Landscape Architects or equivalent and shall have at least 3 years’ working experience on tree transplanting works. The *Contractor* shall agree with the ITS prior to submit and obtain acceptance from the *Project Manager* a detailed method statement and works programme for transplanting the existing trees, outlining the method, sequencing, timing of operations, and the location and type of machinery to be used for the following operations:

(a) Protection before lifting and transplanting,

- (b) Root pruning, including the rootball size, and the number of stages, the operations involved in each stage, and the period between each stage of root pruning,
- (c) Crown pruning including the extent of crown pruning,
- (d) Excavating trenches for rootball preparation including the size of trenches,
- (e) Design and construction of supporting measures,
- (f) Attaching lifting gear to the trees,
- (g) Protection during transit,
- (h) Temporary holding nursery, if required,
- (i) Lifting,
- (j) Transportation to new location, including routing,
- (k) Backfilling and making good the donor site,
- (l) Placement, backfilling, mulching and securing at receptor site,
- (m) Backfilling and making good the donor site,
- (n) Schedule of establishment works during the period for establishment works,
- (o) Securing and supporting measures.

(7) Root activator, where necessary, shall be applied at regular intervals in accordance with the manufacturer's instruction. Root activator shall be a chemical which contains plant hormones GA, and IAA, and which can activate root growth such as "Rootone" or equivalent and accepted by the *Project Manager*.

The following is added after G.S. Clause 3.97(17) :-

(18) Trees to be transplanted shall be inspected for dead, diseased or damaged branches in the presence of the ITS. All crown pruning works to be carried out shall ensure that a balanced crown is preserved, in a way that the character of the tree species is kept. The extent of the crown pruning works shall be determined by the ITS on site and agreed by the *Project Manager*.

(19) The *Contractor* shall also comply with the general requirements as set out in the Appendix 3.1 for carrying out the tree transplanting works under this contract.

(20) The *Contractor* and the specialist landscape *Contractor* shall ensure all the trees transplanted at the Site without topping and hard pruning. For the tree stock delivered, the *Project Manager* should sign and certified that the trees to be planted are not topped or hard pruned.

The following is added after G.S. Clause 3.97 :-

*Root pruning*

3.98

(1) Root pruning should normally take place during the wet season with a minimum of one month allowed for root regeneration between each stage of root pruning. The period of root pruning shall be determined by the ITS and agreed by the *Project Manager*. Three months or more should be allowed between each stage of pruning to ensure maximum fibrous root regeneration prior to the actual uplifting/transplanting operations. The period of root pruning may be adjusted to suit specific tree species and/or imposed contract constraints.

(2) The diameter of the rootball to be cut shall be determined by the ITS and accepted by the *Project Manager*. Normally, the rootball to be cut should be with trunk diameter at breast height to tree diameter ranges from 10:1 according to international standards (except for a palm which may require a smaller root ball) and not less than 1500mm diameter, and 1000 – 1200mm deep to enhance survival rate for transplanting. Method statements should be submitted by the *Contractor* taking into account the size and species of trees, site constraints, arboricultural practices, etc for particular tree(s) for the acceptance of the *Project Manager*.

(3) After determining the size of the rootball and after obtaining the acceptance of the *Project Manager*, the proposed circumference of the rootball shall be marked on the ground around the tree.

(4) The trenches that are made for rootball preparation shall be backfilled with backfilling materials to be accepted by the *Project Manager*, to encourage new growth of root tips. Rootball shall be kept moist from time to time during the preparatory period to stimulate new-root.

(5) Roots shall be cut with a clean sharp knife or similar sharp implement to prevent tearing of the roots.

(6) The *Contractor* shall make regular checks to ensure the stability of the tree and adjustments made accordingly throughout the entire root pruning/crown pruning stages.

- (7) Trees shall be inspected every 28 days by the *Contractor* to check the health of the tree. Any sign of deterioration shall be notified to the *Project Manager* and remedial action taken. The *Contractor* shall water regularly, remove weed growth, fertilize, aerate the soil, folia feed, carry out insecticide treatment and any other horticultural work as necessary and as instructed by ITS.
- Tree lifting and protection* 3.99
- (1) Transplanting shall be carried out during early morning or late afternoon when the sun is not directly overhead. No lifting shall take place during rainfall. Tree shall be transplanted within 2 hours of lifting.
- (2) Wrap trunk and lower branches with accepted hessian and tie with jute string at least one day prior to rootball preparation. Before lifting, the outer edge of the previously dug trenches shall be loosened from the surrounding soil and the rootball undercut to allow the tree to be lifted free from the ground with the rootball intact.
- (3) A crane or lifting device shall be used to secure the tree and support its full weight when lifted without damaging the branches or trunk. No items of hardware shall be inserted into the trunk or branches for lifting or other purposes. Cables used for lifting shall be wrapped with protective rubber sheaf to prevent damage.
- (4) Plants shall be lifted carefully to avoid damage to rootball. Roots shall be cut free from ground, not pulled, using a suitable implement to give a clean cut.
- (5) Where suggested by the ITS, a board shall be placed under the rootball or a rootball box shall be constructed to support the full width and depth of the rootball.
- (6) The ITS shall be present to supervise the work.
- Planting at receptor site* 3.100
- (1) Plants transplanted directly to the receptor sites are to be planted in accordance with the General Specification.
- (2) Prior to the lifting of the trees, tree pits at their receptor sites shall be already prepared and agreed on site. All pits shall be 300-500mm greater than the size of the rootball of the tree to be transplanted at on all sides and bottom. Tree pit base shall be scarified to a depth of 150mm. Loosen the base and sides of the tree pit and fill with water 24 hours before planting to ensure free drainage. Trees shall be transplanted to the new tree pits within 2 hours after being lifted.

(3) Place tree in the pit allowing the top of the ball to be at least 100mm above the surrounding paving level to allow consolidation of the backfill soil. After settlement the top of the root collar shall be level with the surrounding ground level. Backfill in layers, each layer being firmly consolidated to eliminate air pockets. The backfilling materials proposed by the *Contractor* shall be agreed by the ITS and accepted by the *Project Manager*.

(4) Add fertilizer to the backfilling materials at the rate determined by ITS. Alternatively, liquid fertilizer may be used as accepted by the *Project Manager*. Fertilizer shall be thoroughly mixed with the backfilling materials. Hormone powder may be applied to the rootball and alginates and polymer gels mixed into the backfilling materials in accordance with the manufacturer's instructions if suggested by ITS and accepted by the *Project Manager*.

(5) Securing and supporting measures for the transplanted trees shall be submitted by the *Contractor* and accepted by the *Project Manager*.

*Holding nursery for transplanted trees* 3.101a

(1) The *Contractor's* holding nursery for transplanted plants should meet the following requirements:-

General:

- (a) The holding nursery shall be for the purpose of temporary storage of transplanted plant material under this contract. The nursery may not be used for any purpose not directly related with this contract.
- (b) Holding nursery shall be the *Contractor's* own proposed off-site nursery.
- (c) Not used.
- (d) The *Contractor* shall be responsible for the arrangement of land status, utility connections, and any necessary fee payment for the satisfactory operation of the holding nursery within this contract period.

- (e) The *Contractor's* holding nursery shall be within the territory of Hong Kong Special Administrative Region, and be capable to hold at any time all the transplanted trees under this contract and allowance of passageway for maintenance works without disturbance to the transplanted plants. The total area of off site holding nursery shall not be less than 25m<sup>2</sup> times the total number of transplanted trees in one location. The *Contractor* shall allow access to other *Contractors* to transplant trees to this holding nursery.

The *Contractor* shall carry out necessary arboricultural work to maintain the stocked trees in a good and healthy condition during the holding period prior to replanting.

- (f) Prior to forming the holding nursery, the *Contractor* shall submit documents including location plan, updated survey plan with contours information, photographic records, and any other information to demonstrate the nursery can adequately accommodate all the transplanted trees under this contract in a protected environment, for the acceptance by the *Project Manager* within 30 days after the commencement of this contract.
- (g) Once accepted, the holding nursery site shall not be amended without fully justified reasons which are beyond the control of the *Contractor*. Resubmission to the *Project Manager* for acceptance at least six months in advance, is required on proposal of alternative site.
- (h) The *Contractor* shall allow all necessary costs in his Prices for the transit of the plant material between the holding nurseries.
- (i) The boundary of the holding nursery shall be clearly demarcated by minimum 1.2m height fencing, securely erected on the ground without interference to the transplanted plant material.
- (j) Each transplanted trees shall be tagged with a weather proof label with information on this contract number, tree number, originated location and arrival date to the nursery.

- (k) The *Project Manager* shall have rights to inspect the holding nursery at regular intervals and at any one time to verify the condition of the nursery and/or health of the transplanted plant material.
  - (l) The *Contractor* shall maintain the holding nursery in neat, tidy and litter-free condition at all times.
  - (m) The *Contractor* shall provide supply of non-toxic water for the watering of the plant material within the holding nursery. The *Contractor* shall make allowance in the rates for importing of non-toxic water suitable for irrigation during periods of water supply restrictions and/or pipework failure.
- (2) Storage of transplanted trees in the *Contractor's* holding nursery:
- (a) Upon arrival in the holding nursery, the transplanted trees shall stand upright on level ground, in a position where it will be protected from damage and unnecessary movement.
  - (b) If transplanted trees are delivered to the plant nursery with shoots and branches bundled, remove all tyings immediately.
  - (c) Each transplanted tree shall occupy a certain plot of land as determined by the ITS, exclusive of passageway in between for maintenance works. The total occupied area to be used for the holding nursery for the transplanted trees shall be reported by the *Contractor* for acceptance and record by the *Project Manager*.
  - (d) The *Contractor* shall carry out necessary arboricultural work to maintain the transplanted trees in healthy condition during the holding period.
  - (e) The *Contractor* shall water all the transplanted trees as often as required to keep the soil moist around the roots of the plants.
  - (f) Watering shall be carried out either in early morning and/or later afternoon, or both as required.
  - (g) The watering frequency shall be determined by the ITS to ensure the transplanted trees are in healthy condition during the holding period.



- (h) All the transplanted trees that temporarily stored within the holding nursery will be transplanted off site to the permanent receptor prior to the expiry of this Contract period.
- (3) Submission of record:
- (a) The *Contractor* shall submit separate monthly report in a format to be agreed with the *Project Manager* prior to tree transplanting works for the transplanted trees held in the holding nursery including information, but not limited to:
    - (i) Individual transplanted tree with reference to works order number, tree number, species name, originated location, date of arrival in the nursery, expected date for subsequent transplant to permanent location, area of land occupied;
    - (ii) Total quantity of transplanted trees in the holding nursery;
    - (iii) Total area of land occupied by the transplanted trees, excluding maintenance passageway;
    - (iv) Special matters to be reported, such as typhoon damages; and
    - (v) Photographic record of the overall holding nursery.

(4) Tree Transplanting within holding nursery :

If temporary storage of new trees in holding nursery is required transplanting including lifting and temporary storage in the *Contractor's* own or designated holding nursery. All new trees shall be transplanted in accordance with the following procedures:

- (a) The planting of trees lifted from their donor site shall be carried out as specified for new planting, using all recognised horticultural methods and practices for handling, planting, establishment and transportation.

- (b) The *Contractor* shall keep a complete photographic record of the entire transplanting operation at the various stages of work including:-
  - (i) A photograph of the whole tree prior to any work,
  - (ii) Crown pruning,
  - (iii) Root pruning,
  - (iv) Watering,
  - (v) Undercutting,
  - (vi) Excavating trenches for rootball preparation,
  - (vii) Lifting,
  - (viii) Transportation to new location,
  - (ix) Placement, backfilling mulching and securing at new receptor site,

*Temporary holding location for transplanted trees* 3.101b

(1) Temporary holding location is area on site to hold the transplanted trees temporarily. *Contractor* is required to transplant and maintain the trees to temporary holding location instead of holding nursery when instructed and agreed by the *Project Manager*.

(2) The *Contractor* shall be responsible for the arrangement of land status, utility connections, and any necessary fee payment for the satisfactory operation of the temporary holding location within this contract period.

(3) The *Contractor* shall carry out necessary arboricultural work to maintain the trees in a good and healthy condition during the holding period prior to replanting, also ensure the tree supporting is good enough to support the trees.

(4) The requirements under Clause 3.101a in this Section are also applied.

*Post transplanting / Establishment work* 3.102

(1) The transplanted trees shall be maintained immediately after transplanting works, from existing location and maintenance shall continue for a period of time till the expiry of the period between Completion and the *defects date* or such earlier dated as instructed by the *Project Manager*. Such maintenance shall include all measures necessary to establish and maintain all the transplanted trees in an acceptable vigorous and healthy growing condition until the expiry of the establishment Period.

- (2) Immediately after transplanting, the base of all the transplanted trees shall be well watered, using enough water to thoroughly soak the rootball. The transplanted trees should be well watered in evenings and early morning only.
- (3) Watering shall be carried out daily during the dry season, generally September to April.
- (4) Watering shall be carried out as required during the wet season to maintain a vigorous and healthy growing condition.
- (5) Firming up of the transplanted trees and the supporting material shall be undertaken from time to time during the period and particularly after heavy rain and/or wind.
- (6) Root activator, if instructed, shall be applied regularly according to manufacturer's recommendations.
- (7) Fertilize in March and September each year or as directed by the *Project Manager*.
- (8) Rootball shall be kept free of weeds at all times.
- (9) The transplanted trees shall be pruned to remove dead or dangerous branches follow the advice of the ITS.

*Tree surgery works* 3.103

- (1) Tree surgery works shall cover the removal of dead, dying and diseased branches and stumps, cleaning out cavities, raising and thinning the crown for transplanting purposes and generally improving the shape of the transplanted trees.
- (2) All tree surgery works shall be in accordance with good horticultural practice and BS 3998 – Recommendations for Tree Works. No work shall be carried out without the direct supervision of the ITS on site.
- (3) The *Contractor* shall allow and assure all necessary safety precautions/measures are taken to protect those engaged in the operations, as well as people and property in the vicinity (both from within and/or outside site boundary).
- (4) (a) Tree limbs shall be removed in pieces, no more than 400 mm in length;

- (b) To prevent tearing the bark, cut limbs in three operations. The first cut is a shallow notch made on the underside of the branch, outside the branch collar. This cut will prevent a falling branch from tearing the stem tissue as it pulls away from the tree. The second cut should be outside the first cut, all the way through the branch, leaving a short stub. The stub is then cut just outside the branch bark ridge/branch collar, completing the operation;
  - (c) Cut all limbs sloping away from the main trunk at an angle of approximately 60° from the horizontal on a line above the branch bark ridge and the branch collar without leaving a stub;
  - (d) Carefully lower all cut branches to the ground to prevent any damage to limbs being retained.
- (5) Cleanly cut back loose, dead or damaged bark to firm healthy bark, and trim to leave rounded edges.
- (6) Cut out rotten wood from cavities, without exposing clean healthy wood or brush sealant to all open cuts accepted by the *Project Manager* within 20 minutes of making the final cut.
- (7) Repair any damage to the transplanted trees caused by tree surgery operations or any other cause during this contract period, as instructed.
- (8) Tools should be sharp or stubs. Equipment that damage living tissue and bark beyond the scope of the work should be avoided and as recommended by and in accordance with BS 3998.

### **SLOPE GREENING**

#### **GENERAL**

<i>General requirement</i>	3.104a	Slope Greening is a vegetation treatment to the surface of slope such as slope beam or planting medium on slope. It should be carried out at locations/ type as shown on the drawings or as directed by the <i>Project Manager</i> . Hydroseeding (Grass seeds) requirement and procedure of work should be read in conjunction with the detail of GS or as requested by the <i>Project Manager</i> .
<i>Ground preparation</i>	3.104b	Before greening of existing slope, <i>Contractor</i> shall carry out ground cleaning and cultivation with soil conditioner for the surface of the planting medium or any measures required by <i>Project Manager</i> to encourage growing of new planting.

**MATERIALS & EQUIPMENT**

*Hydroseeding/  
 Hydroseeding with  
 shrub seeds mix* 3.105 Seeds are imported in terms of species, varieties and purity. The origin of seed and the name of the supplier should be stated on the container or packing.

(1) The quality of seed should be gauged by purity, germination percentage and freedom from weeds. The total weed seed content should not exceed 0.5% by total mass and the total content of other crop seeds should not exceed 1% by total mass.

The application rate for the Greening work should be as follows :

<u>Grass Species</u>	<u>Application Rate</u>
Bermuda grass ( <i>Cynodon dactylon</i> )	15 gram/m <sup>2</sup>
Bahia grass ( <i>Paspalum notatum</i> )	10 gram/m <sup>2</sup>
Lolium perenne ( <i>Perennial Ryegrass</i> )	5 gram/m <sup>2</sup>
<u>Shrubs Species</u>	<u>Application Rate</u>
Blood-red Melastoma ( <i>Melastoma sanguineum</i> )	15 gram/m <sup>2</sup>
Hong Kong Hawthorn ( <i>Raphiolepis indica</i> )	15 gram/m <sup>2</sup>
Rose Myrtle ( <i>Rhodomyrtus tomentosa</i> )	15 gram/m <sup>2</sup>

Other seed may be selectively added as requested

*Erosion control mat* 3.106 Erosion Control Mat should be made with accepted Geotextile or equivalent materials. It should not be degraded within 5 years after application or until the specified grass cover has been established.

*Wire mesh* 3.107 Wire mesh shall be made from flexible woven wire heavily galvanized, with PVC coating, Mesh diameter 2.2mm, 80mm x 60mm of dimensions with PVC Coated as specified in the CEDD Standard Drawing C2205/C2511.

*Spraying machinery* 3.108 The spraying machinery should be a wet spraying machinery which should be verified by the material supplier in order to facilitate the spraying of fiber soil.

Water and fiber soil ingredients should be readily mixed before loading into the spraying machine.

<i>Particulars of seed mixture</i>	3.109	A certificate or a numbered seed analysis report for each seed mixture issued within 6 months before the date of use of the seed showing the species and variety of the seed, the date of testing and including results of tests :  (a) Percentage of germination of pure seed in a fixed period of time under standard laboratory conditions  (b) Percentage of composition by weight, including details of impurities
	3.110	NOT USED
	3.111	NOT USED
	3.112	NOT USED
	3.113	NOT USED
	3.114	NOT USED
	3.115	NOT USED

#### **METHOD STATEMENT**

Preliminary	3.134	The method statement and procedure of work should be read in conjunction with the detail of the drawing or as requested by the <i>Project Manager</i> . All provisional works should be scheduled according to the different gradients and surface conditions of slopes according to the instruction of <i>Project Manager</i> .
Ground cleaning	3.135	Weeds, rubbish, litter, stones exceeding 50 mm diameter and all deleterious material should be removed from the surface of the ground. Vegetation should be cleared without using herbicide unless permitted by the <i>Project Manager</i> . If permitted, the herbicide should be a proprietary type accepted by the <i>Project Manager</i> and should be applied in accordance with the manufacturer's recommendation.
Fixing of Eco- Bag	3.136	The Eco-Bag filled with fiber soil will be fixed in row or stagger type by using pvc coated galvanized wire string and subanchors.
Fixing of turf reinforcement mat	3.137	(1) Fixing of turf reinforcement mat, anchor and subanchor.  (2) The auxiliary anchor should be fixed at a minimum of 1,000 mm c/c along the crest of the slope.  (3) Minimum 50 numbers of subanchors should be fixed in every 100 m <sup>2</sup> of area.

Extension of weep hole	3.138	If there is weep hole and ranking drain on the slope, it should be extended 100 mm further with similar material in order to avoid blocking of outlet after hydromulching.
Hydromulching	3.139	(1) The fiber soil should be mixed with seed and water in an appropriate proportion.  (2) The mixture will be sprayed by wet spraying machinery onto the surface until reaching thickness of at least 50 mm or covering the thickness of turf reinforcement mat.  (3) Walking on the area that have been hydromulched should be restricted to access unless the fixing protective fabric or the work of patching
Installation of erosion control mat	3.140	The Erosion Control Mat should be laid and fixed with iron staple on the surface of fiber soil layer with anchor at approximate 1,000 mm c/c.  The overlapping of the mat should not more than 50 mm in order to prevent the interruption of the growth of vegetation under the mats.
Installation of wire mesh	3.141	It will be fixed by stainless steel anchor bolt M12 A4-70 x 75mm at approximate 1,000mm c/c along the crest and 2 sides of the slope.  It will be fixed by stainless steel anchor bolt and M12 A4-70 x 75mm to the slope surface at approximate 1,500mm c/c and at the toe of the wire mesh at approximate 1,000 mm c/c respectively.
Pit planting on Eco-Bag	3.142	Excavate a planting pit on the Eco-Bag. water retaining agent should be added to the planting pit. Then the plants should be placed vertically in the pit and adjusted to the required depth and orientation of the crown.
Planting of fern / climber sprig	3.143	Fern / climber sprig will be planted by hand plugging at 500 mm c/c if no planter tubes are installed.
Yard waste management	3.143A	Yard waste generally includes but is not limited to grass clippings, leaves, branches, weeds, tree trunks, cut flowers, bushes and shrubs, festive plants and shall be screened to exclude contaminants, chemical residues, diseased parts of plants, dry and free of soil, etc.  Yard waste is recyclable materials which shall be sorted on site for the purpose of recycling and should not be considered as waste for disposal except for the diseased parts of plants.

All parts of plants carrying diseases or pests have to be bagged and sealed in a strong bag and properly disposed of at designated sites for dumping, such as designated landfill sites to avoid contamination.

The final disposal of the yard waste should be at designated sites for dumping, such as designated landfill sites, site for organic waste conversion, etc. and be subject to *Supervisor's* acceptance.

Where appropriate, the *Contractor* shall be responsible to cut and shred the yard waste in order to meet the collection requirement of the recycling outlet for processing.

At least 10% (the percentage can be adjusted to meet the market supply) of the organic compost and mulches shall be sourced locally. Proper documentation indicating the source of origin shall be provided for *Supervisor's* acceptance.

### **ESTABLISHMENT WORKS**

Establishment works	3.144	(1) Establishment works should be carried out for the period stated in this contract and in accordance with Clauses 5.04 to 5.06.  (2) All necessary measures should be taken to ensure that grass and ground cover become well-established and to keep the area tidy and free from litter and rubbish.
Inspection of establishment works	3.145	An inspection of Greening work and the establishment works should be carried out jointly by the <i>Contractor</i> and the <i>Project Manager</i> at monthly intervals when required. The <i>Project Manager</i> should instruct the <i>Contractor</i> to carry out establishment works when necessary; the work instructed should be completed within 14 days after the date of the <i>Project Manager</i> 's instruction.
<i>Replacement of vegetation</i>	3.146	Vegetation coverage of 90% of the area should be achieved at the end of the period for establishment works. The vegetation should be healthy and free from weeds. Areas which are considered unsatisfactory by the <i>Project Manager</i> should be reseeded by hydroseeding as stated in General Specification.



Watering	3.147	<p>(1) Fresh water should be used for watering for Slope Greening System. Water should be applied using a hose or any type of sprinkler agreed by the <i>Project Manager</i> and in such a manner that compaction, washout of loosening material will not be caused; any damage caused should be made good immediately.</p> <p>(2) After spraying, watering should be carried out every 7 days. The minimum requirement for watering should be 10 litres/m<sup>2</sup>. The <i>Contractor</i> may apply for the <i>Project Manager's</i> agreement for relaxation of the requirements in the event of heavy rainfall.</p> <p>(3) Watering should be conducted until the vegetation is satisfactorily established.</p>
Grass cutting	3.148	<p>(1) The inspection of grass cutting should be carried out twice a year at 5th month and 11th month after completion of work.</p> <p>(2) Grass should be trimmed along the boundary of hydromulched area, if the climber spread outside the hydromulched area more than 500 mm.</p> <p>(3) Grass shall be reduced by cutting to a height of 100mm when it reaches 300 mm height.</p>
Control of pests and fungi	3.149	Pesticide or fungicide should be applied in accordance with the manufacturer's recommendations to control pests and disease.
Completion of work	3.150	Immediately before the end of the period for establishment works :  (a) all planted and grassed areas should be free from litter;  (b) all replacement and patching up of vegetation should be completed;  (c) all vegetation edges trimmed.

#### TESTING OF VEGETATION COVERAGE

Testing of vegetation coverage	3.151	<p>(1) Tests should be carried out to determine the vegetation coverage. The tests should be carried out 100 days after grassing and at the end of the period for establishment works. The vegetation should be cut to a height of 300 mm if necessary over the parts of the area to be tested.</p> <p>(2) The number of tests should be instructed by the <i>Project Manager</i>.</p> <p>(3) Tests should be carried out at location which is chosen by the <i>Project Manager</i> to represent the grassed area as a whole. At each test location an approximate area of 10 m<sup>2</sup> should be marked.</p>
--------------------------------	-------	---

Compliance criteria of vegetation coverage	3.152	At least 90% of each test area should be covered with vegetation unless the existing gradient of the slope is greater than that from design, or it is a shaded area which is not suitable for vegetation growth.
Non-compliance of vegetation coverage	3.153	If the result of any test for vegetation coverage of Slope Greening System works does not comply with the specified requirements for vegetation coverage, the area should be rehydroseeded or reseeded as stated in General Specification, depending upon the size of the defective area, as instructed by the <i>Project Manager</i> .

- End of PS Section 3 –

**PS APPENDIX 3.1**

**TREE TRANSPLANTING**

**(P.S. CLAUSE 3.97(19))**

**[BLANK PAGE]**

## APPENDIX 3.1

### TREE TRANSPLANTING

#### 1.1 TRANSPLANTING OF EXISTING TREES

All transplanting works should ideally be undertaken in early spring (March to October) to increase the chances of the trees' successful re-establishment. Transplanting operation should be timed so as to avoid strong sun or drying winds. The new position or storage facilities should be prepared before the tree is moved, so that the tree can be repositioned within two hours of lifting. The trunk and major boughs should be wrapped in damp hessian to protect from damage in transport and to reduce transpiration. Anti-transpiration spray can also be used on foliage. Crown thinning before transplanting is recommended. All stages of transplanting should be supervised or preferably undertaken by qualified arboriculturalists. The method to be adopted by this contract shall be submitted for acceptance of the *Supervisor* prior to work execution.

#### 1.2 TREE SURGERY WORKS

Tree pruning and thinning should be carried out as instructed by the *Supervisor* during the preparation period before transplanting. All tree surgery work should be in accordance with British Standard 3998 (1989) "Recommendations For Tree Work". Minor pruning of additional limbs may be required after replanting.

#### 1.3 SEQUENCE OF TRANSPLANTING OPERATIONS

Transplanting operations should be in accordance with British Standard 4043 (1989) "Transplanting Root-balled Trees". Preparation for moving should ideally begin several months before the transplanting operation is required (See Fig. 2.1).

- (a) A root ball area which incorporates at least half of the area of the tree crown should be marked out and later a trench is dug around this area. Roots should be carefully pruned and treated with an accepted fungicidal gel. Ideally this operation should be completed at least 6 month before moving so that the tree can establish new fibrous root within the rootzone. The root zone should be watered. A root feed with an accepted slow release fertiliser is recommended.
- (b) Crown thinning and shaping should be undertaken during this period.
- (c) The rootball size for transplanted trees should be a minimum of 1500mm in diameter, and 1000 - 1200mm in depth.
- (d) Precautions against desiccation can include hessian wrapping or anti-transpiration paints and these should be applied before transplanting operations begin.
- (e) The rootball should be kept intact with all soil. At lifting, a spade or specialised lifting bucket can be slipped under the rootball and a strip of hessian or geotextile fabric pulled around the rootmass. The rootball and tree should be kept moist at all times.
- (f) The whole tree should be lifted, using specialised plant if necessary, and moved to its new position within 2 hours. The new planting position should be prepared as for any new tree, using fertiliser in the backfill material and soil conditioner as necessary. The tree should be orientated to best suit the new position and thoroughly watered in.

- (g) The tree should be firmly secured using either well anchored guys, with ratchet turnbuckles for adjustment, or a sturdy bamboo tripod arrangement (with poles of a minimum diameter of 75mm), as instructed by the *Supervisor*. Ties should be adjustable and should include wrapping to prevent chafing.
- (h) Watering should be thorough and regular (at least twice a week) for the first months of establishment.
- (i) Any damaged or additional branches should be pruned after planting.
- (j) The *Contractor* should keep an accurate photographic record (dated), of all stages of the transplanting operation for submission to the *Supervisor*.
- (k) Transplant trees of special conditions such as over-mature size, leaning growing form, wall tree etc. to be subject to special requirements as listed below and method statement for *Supervisor* prior acceptance is a must:-
  - (i) Over-Mature Size (DBH over 500mm)
    - at least 6 months of time or more shall there be for root-ball preparation works before transplanting operations to be carried out;
    - size of prepared root ball shall conform to clause 1.03 (a) and with the minimum size not below 2500mm width and 1000mm depth;
    - due to weight of the tree exceeding normal situation, the anchor point for tree lifting during transplanting might not on the tree main trunk on the opinion of the *Supervisor* and/or depend on situation (i.e. tree species);
    - extensive pruning shall be avoided and pruning works shall be under *Supervisor* supervision;
  - (ii) Leaning Tree
    - adequate temporary support shall be provided to severe leaning tree during preparation period, at where anchor roots are severed for root ball preparation;
    - after transplanting, tree shall be positioned in manner of up-straight and without suffocation of the root zone;
    - tree pruning to be carried out as necessary to encourage balance and symmetric tree form.
- (l) For transplanting of tree at vicinity of residents or public road etc., the *Contractor* shall be responsible to the public safety and exercise maximum effort to avoid causing any damage and disturbance to the mentioned; unless solid proof is provided by the *Contractor* that the situation is out of their control, the *Contractor* shall assume any cost and liability incurred.
- (m) The overall shape of the tree should be maintained after pruning.
- (n) Photo record of the complete tree transplant process should be submitted for the *Supervisor* to review.

#### 1.4 MAINTENANCE WORKS

(a) Maintenance in Temporary Position

When transplanted plants cannot be immediately re-planted in the intended final position, a secure, sheltered and otherwise suitable storage nursery should be designated by the *Contractor* for acceptance by the *Supervisor*. Keeping transplanted trees in the temp position within this period will be the same as for the Establishment works, (see below), but will not constitute part of the Establishment Period. The length of temporary off-site maintenance will vary from contract to contract.

(b) Establishment Works

Establishment works are those works to establish the transplanted tree and to be carried out during the Establishment Period. These works are treated as outstanding works when the transplanting tree is replaced.

(c) Establishment Period

The Establishment Period should extend through at least one growing season from the date of the completion of the replanting works certified by the *Supervisor*. This would normally correspond to a period of 12 months as required.

(d) Dead Plants

The *Contractor* will replace any plant which in the opinion of the *Supervisor* dies, is seen to be dying, or fails to thrive, during this period as a result of bad workmanship, poor quality maintenance or neglect.

(e) Replacement Planting

Replace dead or ailing plants as Clause 1.04(d) within two (2) weeks of being identified, the largest available good quality nursery stock, but at least mature size, of similar species unless otherwise instructed by the *Supervisor*.

(f) Mature Trees

Mature Trees to have all the following characteristics:-

- (i) a sturdy, straight stem, not less than 2000mm in height from soil level to the lowest branch,
- (ii) a stem diameter, greater than 300mm when measured at a point one metre above the root collar.
- (iii) a well balanced branching head, or a well defined straight and upright leader with branches growing out from the stem with good symmetry, and a minimum length of 1500mm,
- (iv) a total height above soil level greater than 7000mm,
- (v) "grown on" in China,
- (vi) a root ball not less 1200mm in diameter and 1000mm in depth,
- (vii) a root system previously under cut a minimum of one year prior to lifting, to encourage compact fibrous growth.

(g) Damaged Plants due to Vandalism

The *Contractor* is not responsible for replacing dead or damaged stock resulting from proven vandalism. The onus is at all times on the *Contractor* to prove that death or damage was so caused by circumstances beyond his control and in any event, no claim shall be considered unless submitted in writing to the *Supervisor* within three working days of the event happening.

(h) Damaged Plants due to Typhoons

Within 48 hours of Typhoon signal No. 8 or above being lowered, replant all plants blown over, firm up all other plants, provide the *Supervisor* with a photographic record of the Site, and prepare a detailed report of all plants which have suffered structural damage. As soon as practical thereafter remove dead plants and clear the Site of all debris providing the replanting works are carried out each day. "The *Employer*" will accept responsibility for dead or dying plants recorded one month after the typhoon, excepting those plants recorded as being dead or dying prior to the typhoon. Thereafter responsibility reverts to the *Contractor*. Should the replanting not be carried out within the time period, or the works not carried out satisfactorily, then the *Contractor* shall be held responsible for all plant re-placements.

(i) Records

Ensure that the accepted Foreman reports to the *Supervisor's* office before and after carrying out the day's maintenance work and make a countersigned record of the work carried out available for inspection at that office. These reports shall contain operations undertaken or specific tree locations and materials used. Provide monthly photo record showing the condition of the plants.

(j) Water

The *Contractor* is required to provide non-toxic water throughout the establishment period.

(k) Weeding

Keep all planted areas weed-free. Undertake a weeding operation at least once a month. Replace any aggregate or soil disturbed or removed during this process.

(l) Weed Disposal

Collect all weeds and rubbish during these operations and remove from the Site to a properly designated tip.

(m) Firming Up

Undertake firming-up of plants from time to time during the period and particularly after heavy rain and/or wind.

(n) Tree Ties

Tighten, or slacken tree ties as necessary for the healthy growth of the tree, and adjust or replace the protective pad as necessary to prevent chafing of the bark.



(o) Pruning

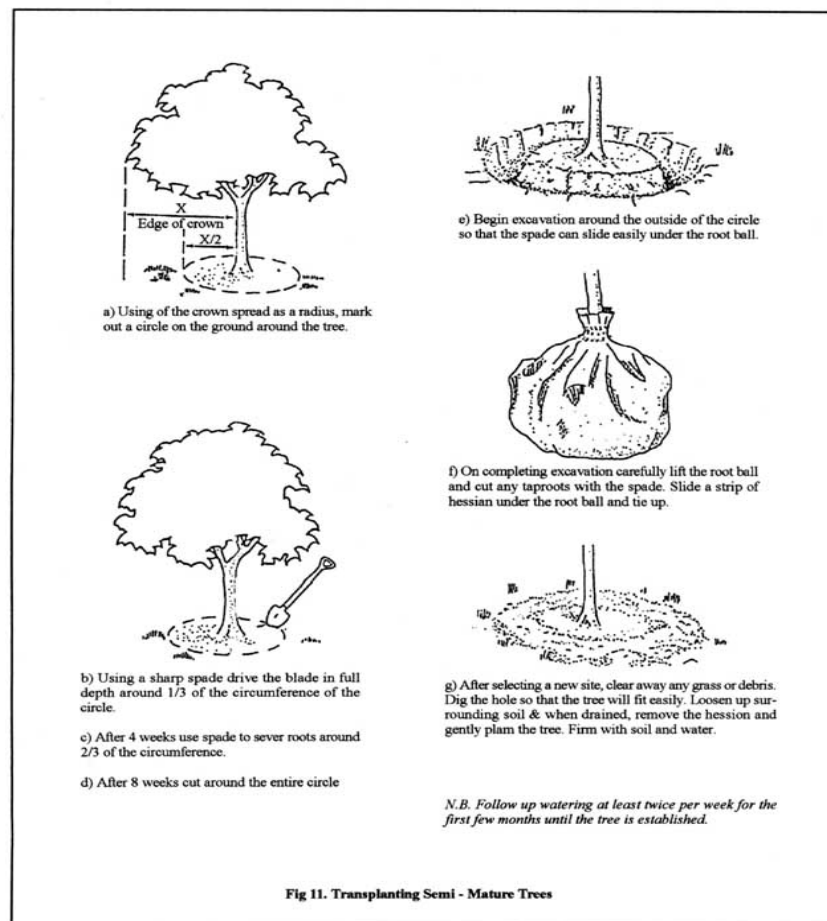
Carry out pruning when instructed during the Establishment Period, to encourage bushy growth good form. Remove dead, damaged or crossing branches.

(p) Pests and Fungal Growth

Regularly check for any insect attack or fungus infestation particularly during known periods of activity. Report to the *Supervisor* any such occurrence and carry out remedial measures by use of sprayed effective accepted insecticide or fungicide in strict accordance with the manufacturer's instruction. Take due care and have regard to the safety and convenience of the general public and carefully control the spraying to avoid unnecessary dispersion.

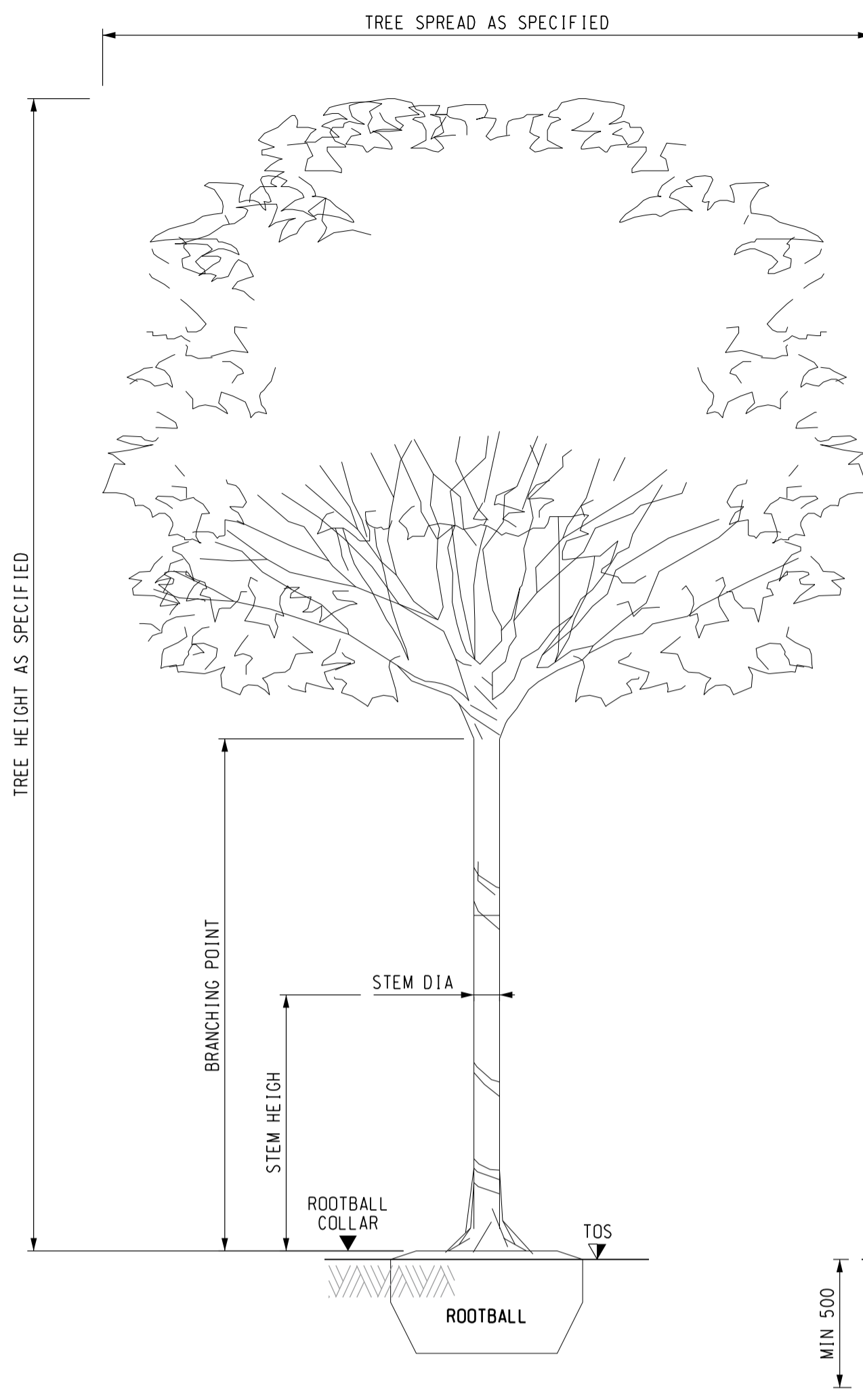
(q) Final Handover

Carry out an inspection and formal check of the works at the end of the Establishment Period, with the *Supervisor*. Carry out the final visit for all regular operations included in the specification, immediately prior to the final handover of the transplanted trees.

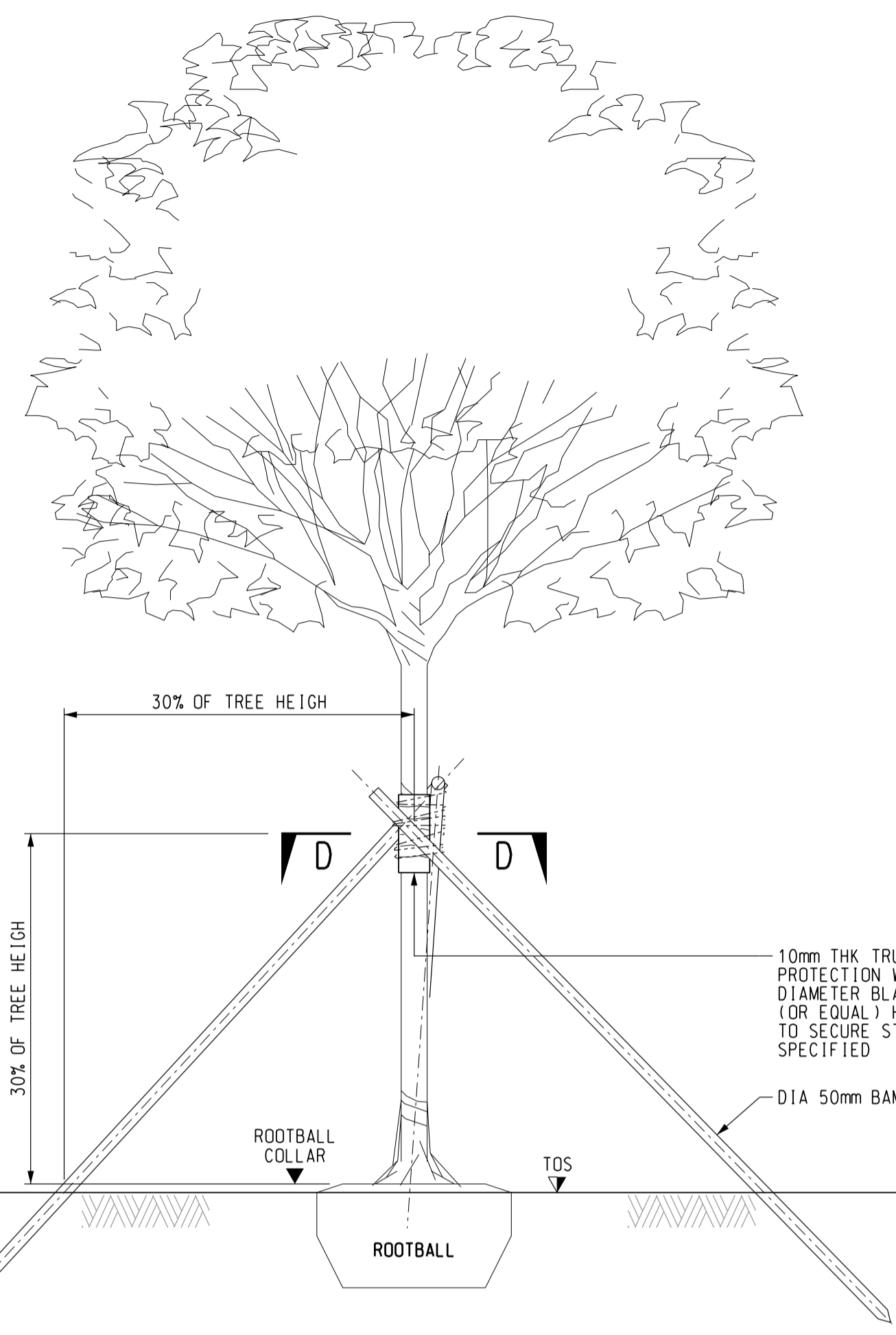


**Fig.2.1 Transplanting Stages**

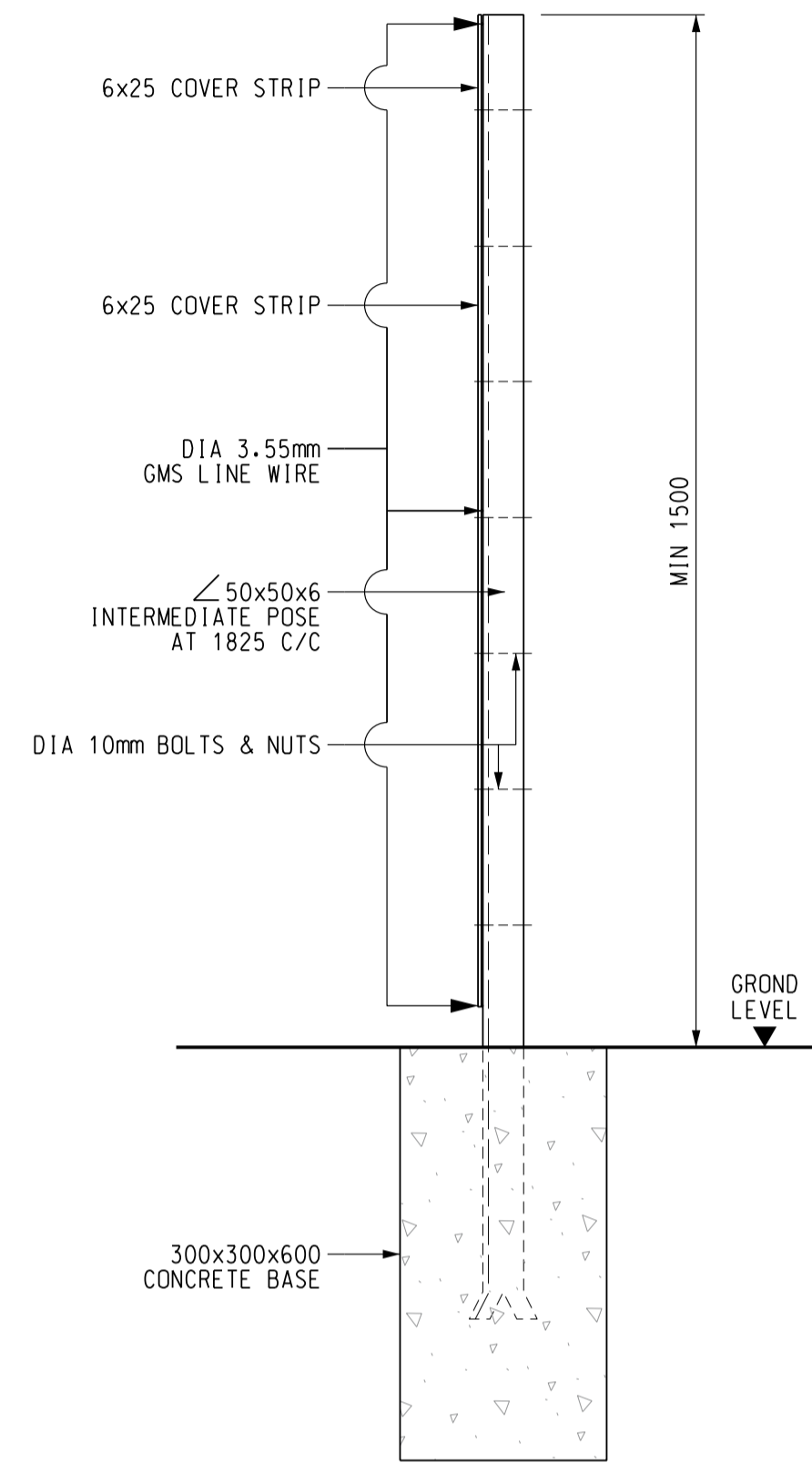
**[BLANK PAGE]**



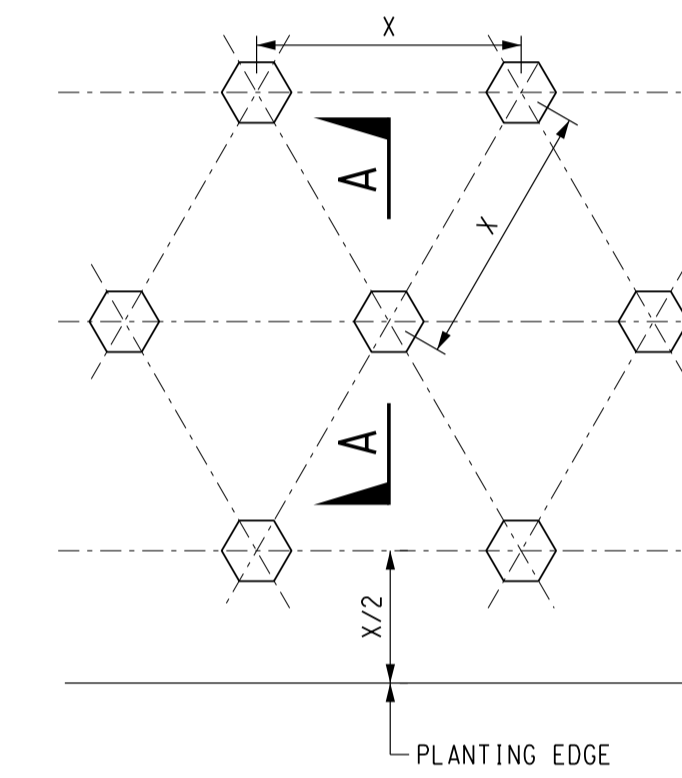
**TREE MEASUREMENT DETAIL**  
SCALE N.T.S.



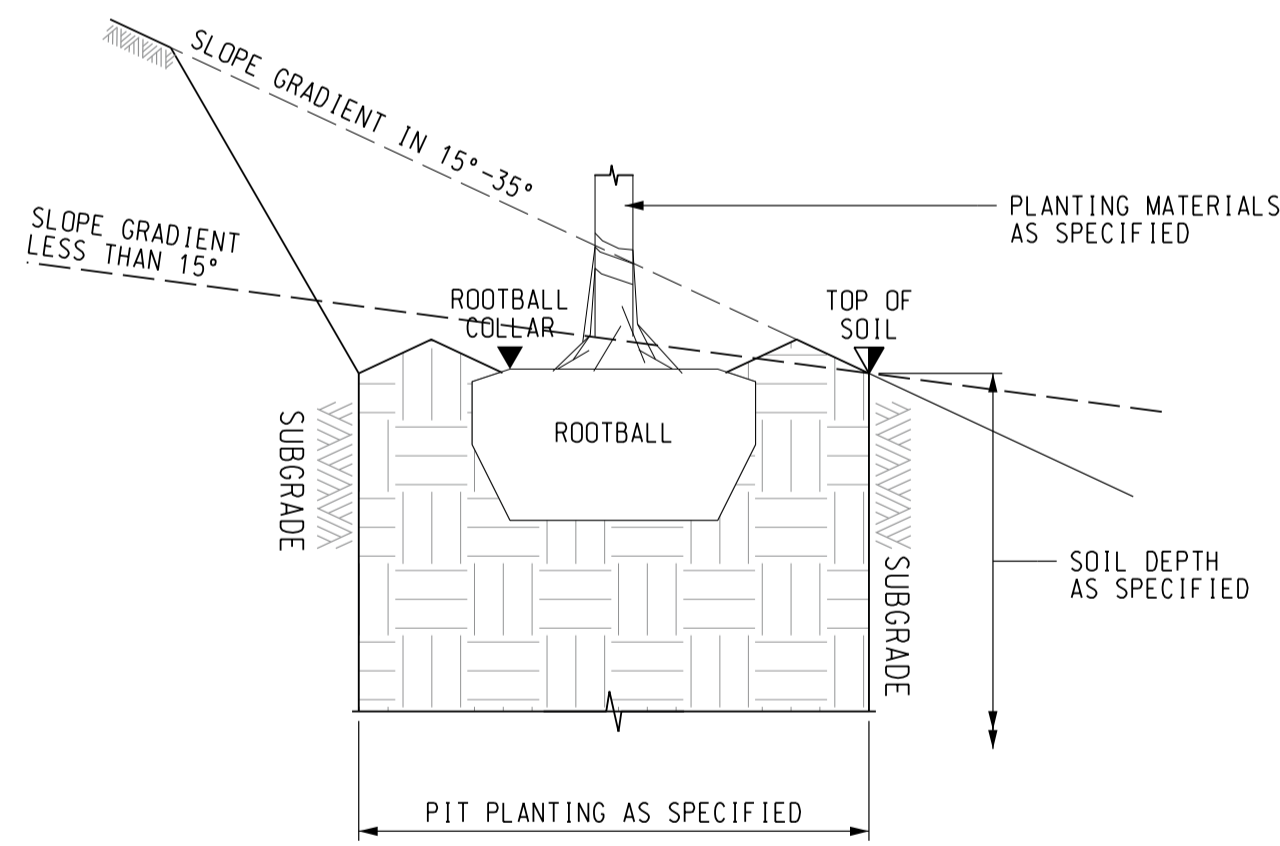
**TREE BAMBOO STAKE DETAIL**  
SCALE N.T.S.



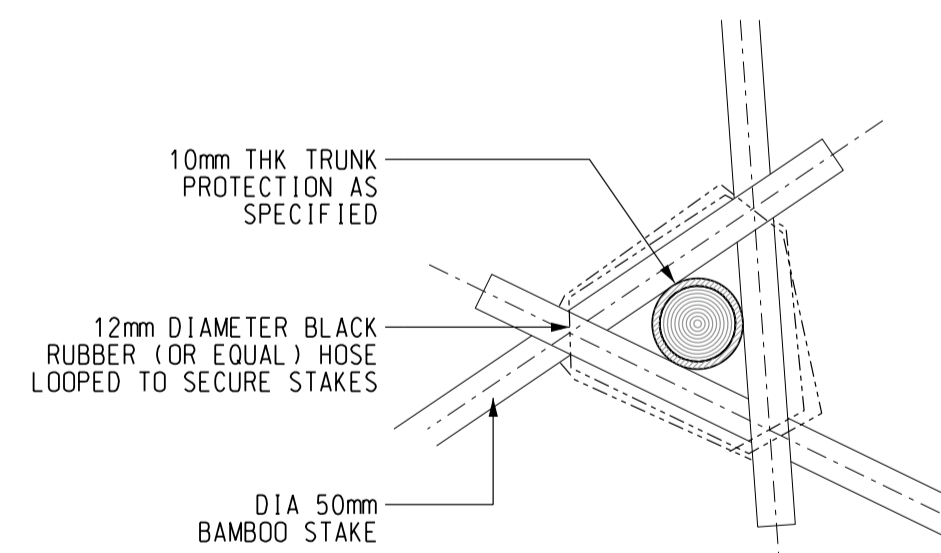
**TYPICAL DETAIL OF TREE PROTECTION FENCE**  
SCALE 1:20



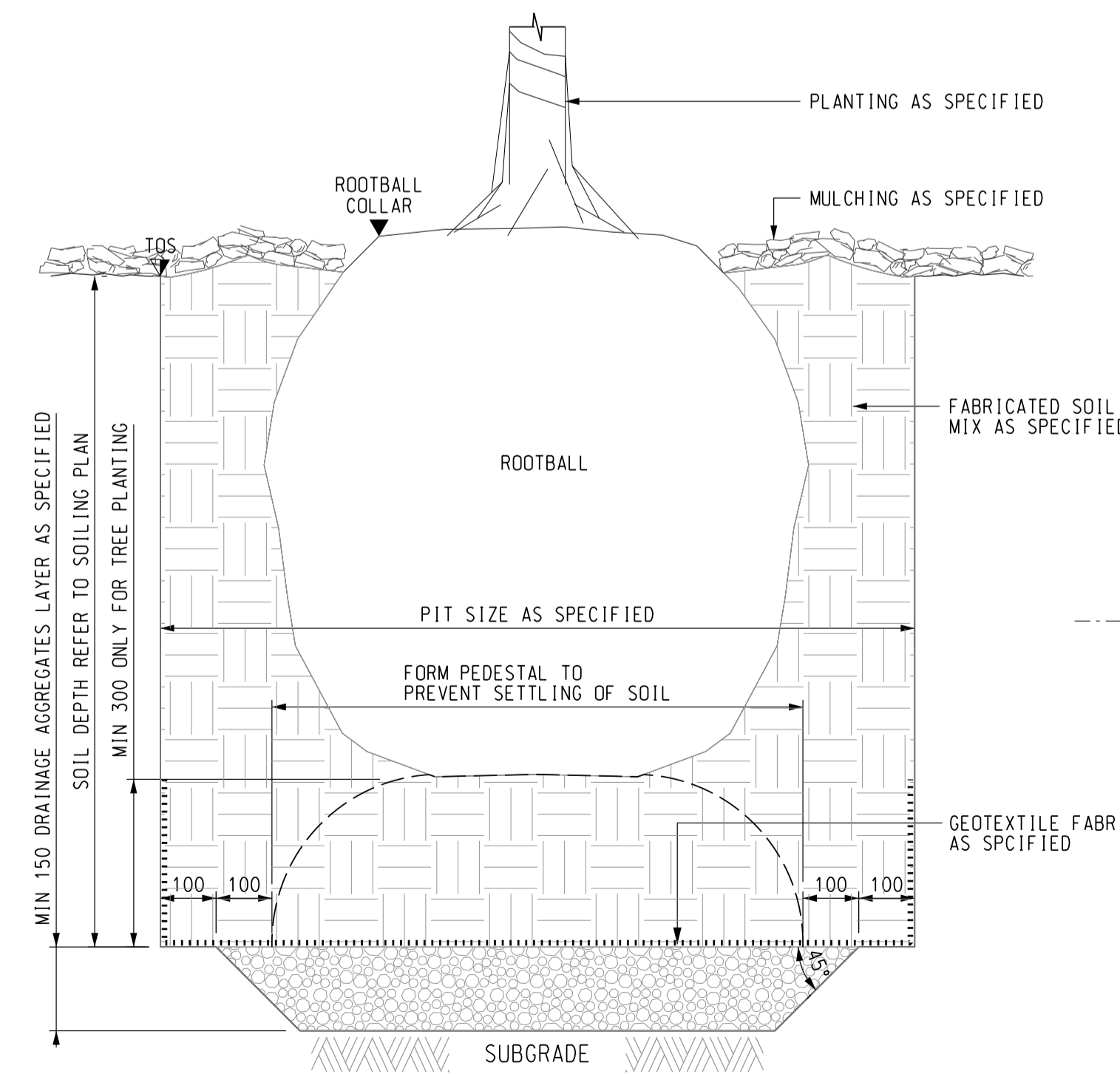
**PLANTING FORMAT IN TRIANGLE SETTING**  
SCALE N.T.S.  
(X = SPACING)



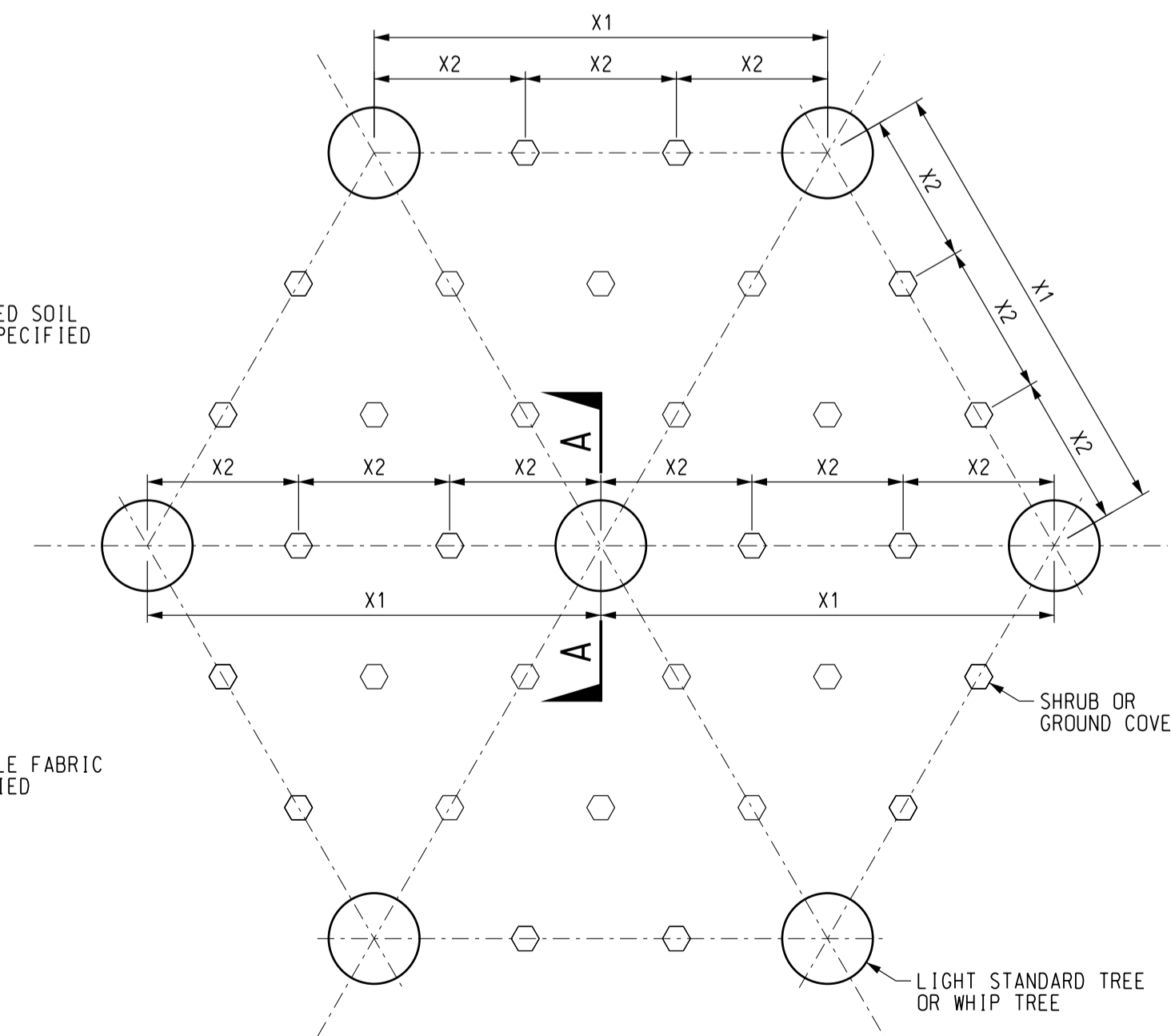
**SECTION B-B**  
SCALE N.T.S.



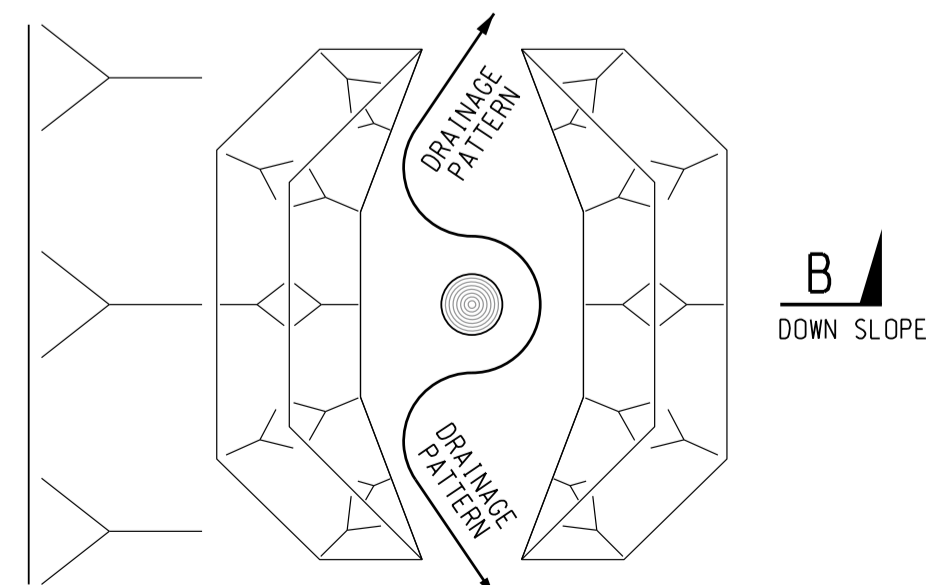
**SECTION D-D**  
SCALE N.T.S.



**SECTION A-A**  
SCALE N.T.S.



**WOODLAND MIX PLANTING FORMAT IN TRIANGLE SETTING**  
SCALE N.T.S.  
(X1 AND X2 = SPACING)



**TYPICAL PLAN OF SLOPE PIT PLANTING**  
SCALE N.T.S.

**NOTES:**

- FOR GENERAL NOTES, COMMON LEGEND AND ABBREVIATIONS REFER TO DRAWING 60328348/R&P/1701, UNLESS OTHERWISE STATED.
- THIS DRAWING TO BE READ IN CONJUNCTION WITH DRAWING NOS. 60328348/R&P/1731 TO 1768, UNLESS OTHERWISE STATED.

**PROJECT**

DEVELOPMENT OF ANDERSON ROAD QUARRY SITE - INVESTIGATION, DESIGN AND CONSTRUCTION

CONTRACT TITLE  
DEVELOPMENT OF ANDERSON ROAD QUARRY SITE - ROAD IMPROVEMENT WORKS AND PEDESTRIAN CONNECTIVITY FACILITIES WORKS PHASE 2A

**CLIENT**

CEDD 土木工程拓展署  
Civil Engineering and Development Department

**CONSULTANT**

AECOM Asia Company Ltd.  
www.aecom.com

**SUB-CONSULTANTS**

**ISSUE/REVISION**

NO.	DATE	DESCRIPTION	CHK.
-	OCT. 17	TENDER DRAWING	AWYC

**STATUS**

STATUS

**SCALE**      **DIMENSION UNIT**

A1 AS SHOWN      MILLIMETRES

**KEY PLAN**

KEY PLAN

**PROJECT NO.**      **CONTRACT NO.**

60328348      NE/2017/03

**SHEET TITLE**

TYPICAL PLANTING DETAIL

**SHEET NUMBER**

60328348/R&P/1951

This drawing has been prepared for the use of AECOM's client and may not be used, reproduced or relied upon by third parties, except as agreed by AECOM and its client, as required by law or for use by governmental reviewing agencies. AECOM accepts no responsibility, and denies any liability whatsoever, to any party that modifies this drawing without AECOM's express written consent. Do not scale this document. All measurements must be obtained from scaled dimensions.